

*Ballistic  
Lub*

THE LAMPS WITH



BEHIND THEM



# Mazda lamp

## CATALOGUE





# Mazda

**lamps stay brighter longer**

*As efforts are made constantly to improve designs and methods of manufacture, subject to statutory restrictions and availability of materials, the goods supplied may differ in details from the description given in this publication.*

# Making Mazda Coiled Coil Lamps



The metallurgy of Tungsten is unusual. It is an extremely hard metal, and its melting point is higher than any of the elements except Carbon. The treatment of both ore and the metal itself is complicated and difficult.

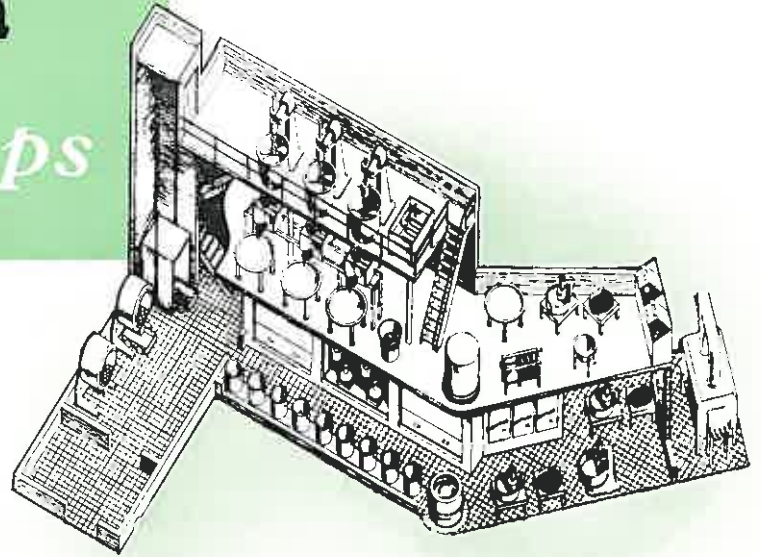

Grinding the ore.

Conversion to Ammonium Para-tungstate.

Crystallisation of Ammonium Para-tungstate.

Conversion to Tungstic Acid, and drying.

Reduction to Tungsten Metal.

## SCHEELITE TO TUNGSTEN POWDER



Scheelite (Calcium Tungstate) is tungsten ore. The ore is ground in ball mills to a uniform fineness. It is weighed and taken to the extraction gallery, where the first chemical process takes place.



Rubber-lined steel vats contain steam-heated Mureatic Acid. The powdered ore is run into the vats, and Tungstic Acid is precipitated. The addition of Ammonia causes a further conversion to Ammonium Para-tung state.



The Ammonium Para-tungstate is evaporated in steam-heated stainless steel evaporating pans. The resulting crystals are washed, dried and ground to a uniformly fine powder.



The Para-tungstate crystals are added to boiling Caustic Soda. Dilution of the resulting solution, and the addition of Hydrochloric Acid cause re-precipitation of Tungstic Acid, but in a much purer form.



The purified Tungstic Acid is washed, centrifuged, baked to complete dryness and once more ground to a uniform fineness. It is "vitalized" by the addition of silica and alumina, and is then ready for conversion to Tungsten metal.



The reduction furnace consists of a number of tubes, and the Tungstic Acid is heated to a uniform controlled temperature. A stream of Hydrogen passes through the tubes and the Tungstic Acid is converted to powdered Tungsten.



# THE TUNGSTEN FILAMENT WIRE



*Quality*

## CONTROL

High and consistent quality of the tungsten is essential. In all the stages from the grinding of the crude ore to the cleaning of the finished wire, this is ensured by scrupulous attention to times, temperatures, and qualities of the materials used. But checks are still made on the finished product.



Powdered Tungsten is compressed, at ten tons per sq. inch, and it emerges as bars.



After swaging, the rod is drawdown into wire. The initial drawing is done through dies of tungsten carbide.



The bars are pre-sintered by being passed through the tubes in a furnace.



The finer drawing is through diamond dies.

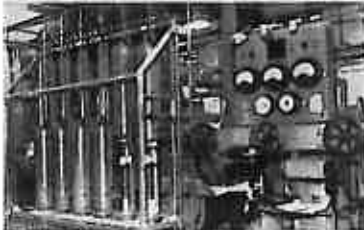

The sintering proper is done by passing a heavy current through the bars in an atmosphere of hydrogen.



Drawing is continued until the required diameter is reached.



The sintered bar is coarse swaged. It is heated, inserted into a pair of rotating dies and hammered.



The last process is cleaning the wire. Colloidal graphite is used as a lubricant and protection during drawing, and this is removed in a caustic soda bath.



Smaller and smaller dies are used as swaging continues.

In all, the tungsten metal is subjected to some sixty to seventy processes before it is ready for coiling as filament wire.



The tensile strength of the wire is checked at precise stages of production.

The diameter of the wire is determined by weighing a known length.

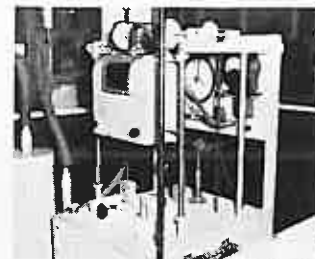

A filament must remain absolutely rigid when incandescent. To test this, current is switched on and the middle support removed.

The wire must also be truly circular.



To test the wire for uniformity of diameter it is heated to incandescence and closely examined.

# COILING MAZDA FILAMENTS

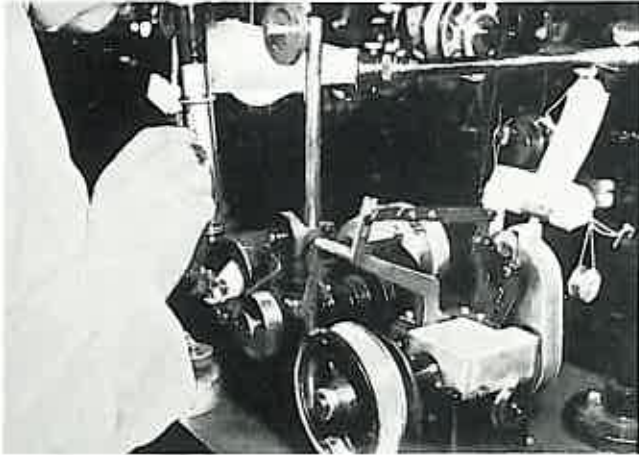

**T**HIS machine is coiling tungsten wire into filaments for Mazda lamps.

The core or mandrel on which the tungsten is wound is dissolved before the filament is assembled in the lamp.

Over 3 feet of wire, of a diameter of 0.00122 inches, is used to make a coiled-coil filament for a 60 watt lamp. When coiled the filament has over 3,500 turns reducing its total length to just over 1 inch. The gap between each turn is as little as 0.000673 inches and this gap must always be maintained.

This whole process is a marvel of manufacturing precision and just one of the many reasons why



## MAZDA LAMPS STAY BRIGHTER LONGER

An electric lamp is inexpensive and taken for granted by everyone. But it is, in fact, a complicated and intricate assembly of the most varying elements. Tungsten, glass, nickel, and copper—special resin—cement, brass and solder enter into the construction, as well as the gases nitrogen and argon.



The basis of almost all G.L.S. lamps is a glass "flare", a glass rod, an evacuation tube and two leads. Each lead comprises lengths of nickel and Dumet metal, a sealed cartridge fuse and finally copper, welded end to end.

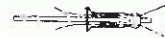

The parts are then combined by heat to form a "stem", and the Dumet middle sections of the leads are sealed into the glass to form a gas- and air-tight union.



The tails of the filament are clinched into the nickel ends of the leads, which are then bent clear of the glass rod while it is heated and filament supports are bedded into place in it. The filament is then re-positioned and secured by the support wires.

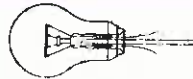
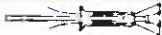

The mount is sealed into a glass bulb. While still hot, the neck is "dimpled" to form a key for the cap cement.

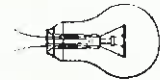

The bulb portion of the lamp is complete only when it has been completely exhausted of all air, when a quantity of argon gas has been introduced, and when the glass tube has been sealed.

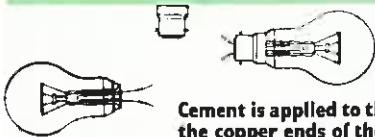

Cement is applied to the cap, the copper ends of the leads are passed through two holes in it and it is pressed down.



The cap is heated to cure the resin-cement. The leads are cut to length and the contacts fluxed and soldered.

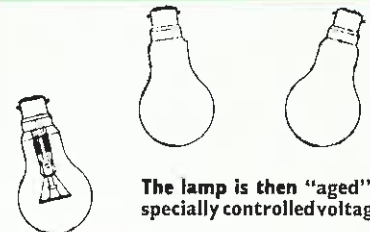

The lamp is then "aged" at specially controlled voltages.

## ASSEMBLY AND TESTING



Inspecting the filament by projection on to a screen. The stem with the complete filament is examined before it is sealed to the bulb.



This machine is exhausting the bulb of air and filling it with argon gas.



The capping machine. The operators are threading the leads through the cap.



A general view of the lamp assembly line.



# INDEPENDENT INSPECTION

Quality control comes into every stage of manufacture but in addition, and to make doubly sure that the highest standards are maintained, there is continuous independent inspection.

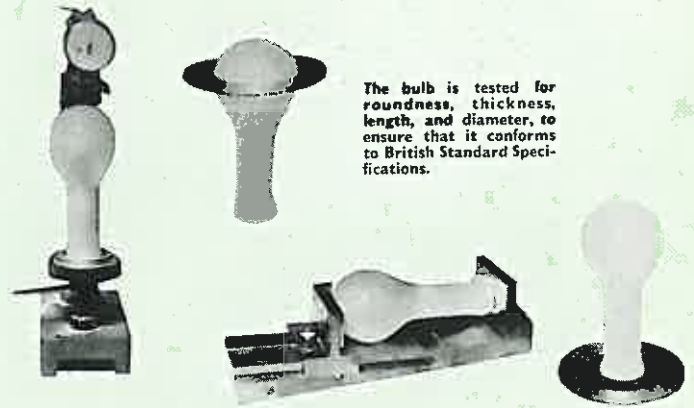

The bulb is tested for roundness, thickness, length, and diameter, to ensure that it conforms to British Standard Specifications.

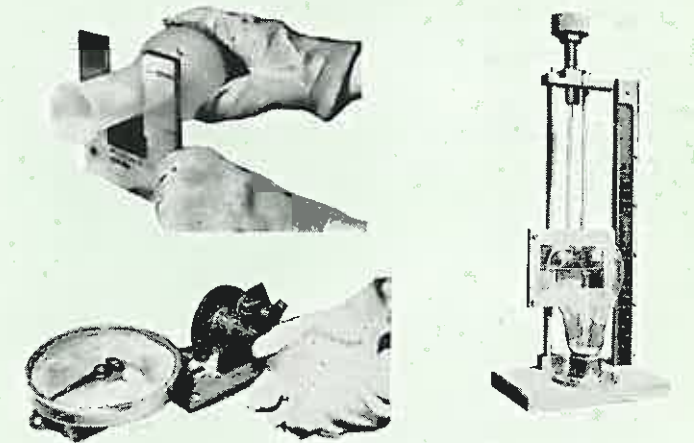

Completed lamps are torsion tested for adhesion of the cap to the bulb.

The filament height is checked to ensure that it is within the specified limits.

There is visual inspection, and accelerated "life" testing by means of calculated over-voltages. The amount of light given by the lamp is measured in photometric spheres.

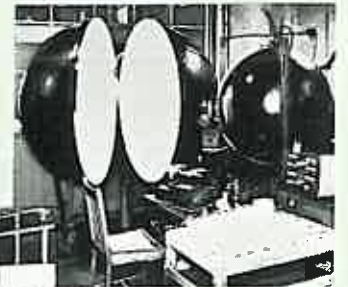

In another test the lamp is swung like a pendulum and the impact is measured when the swing of the lamp is stopped at the bottom. Full-length life tests at the rated voltage are also made on lamps selected at random.

# CONTENTS

## LAMPS

	Page		Page
<b>General Lighting</b>		<b>Photographic</b>	
Clear .. .. .	8	Reflector Spotlight .. .. .	11
Pearl .. .. .	9	Photo-Flood .. .. .	16
Silverlight .. .. .	10	Photographic Pearl .. .. .	16
Fluorescent .. .. .	12 & 13	Photographic Enlarger .. .. .	16
Neon (Type "N") .. .. .	24	Colour Photography .. .. .	16
Traction .. .. .	24	Flash Tubes .. .. .	17
Rough Service .. .. .	24	Speed Midget .. .. .	17
<b>Fluorescent Lamps</b>		No. 5 Flash .. .. .	17
Type MCF/U .. .. .	12 & 13	No. 22 Flash .. .. .	17
<b>Decorative Lighting</b>		<b>Projector</b>	
Light Tubes .. .. .	14	Class A 1 .. .. .	18 & 19
Tubular .. .. .	15	" A 3 .. .. .	20
Longlite .. .. .	15	" B 1 .. .. .	20
Candle .. .. .	15	" E .. .. .	21
Colour Sprayed .. .. .	26	" F .. .. .	21
Sign .. .. .	26	" G .. .. .	22
Disneylights .. .. .	25	Tubular Floodlight .. .. .	22
Fairy Lights .. .. .	25	Studio Spotlight .. .. .	23
Fairy Candles .. .. .	25	Broadside .. .. .	23
Snow Gem Fairy Lights .. .. .	25	Colour Temperature .. .. .	23
<b>Automobile (for Motor Cars, Motor Cycles and Commercial Vehicles)</b>		Reflector Spotlight .. .. .	11
Headlamps .. .. .	30 & 31	Reflector Floodlight .. .. .	11
Side, Tail, Dash .. .. .	32	<b>Miscellaneous</b>	
Stop and Stop/Tail .. .. .	32	Hospital Theatre .. .. .	23
Indicator .. .. .	32	Cruciform .. .. .	24
Festoon, Trafficator .. .. .	32	Neon (Type "I") .. .. .	24
Bus, Interior .. .. .	32	Current Polarity Indicator .. .. .	24
Cycle Dynamo .. .. .	33	Switchboard Indicator .. .. .	24
<b>Electric Discharge</b>		Infra-Red .. .. .	27
Cold Cathode .. .. .	13	Flashlight .. .. .	33
Flash Tubes .. .. .	17	Radio Panel .. .. .	33
Mercury Vapour		Vacuum Police .. .. .	33
(Types MB/V, MA/V and MA/U)	36	Miners .. .. .	34
Mercury Vapour		Aircraft .. .. .	35
(Types MBF/V and MAF/V) ..	37	Lamp Outlines .. .. .	40 & 41
Sodium Vapour (Type SO/H) ..	38	Lamp Caps .. .. .	42 & 43
Mercury Vapour		Lamp Efficiencies .. .. .	44
(Types MBW/V and ME/D) ..	39		

## EQUIPMENT

	Page		Page
Lampholders .. .. .	45	Fluorescent Fittings .. .. .	48 & 49
Lamp Auxiliary Gear .. .. .	46 & 47	'Rugby' Range .. .. .	50
		Streetlighting Lanterns & Floodlights	51

## GENERAL INFORMATION

	Page		Page
Mazda Lamp Publications .. .. .	52	Purchase Tax .. .. .	55(Ext)
Lamp Packing Quantities .. .. .	56	Lamp Classification .. .. .	56(Ext)
Ready Reckoner .. .. .	55	BTH Branch Office Addresses .. .. .	54

PRICES IN THIS CATALOGUE APPLY ONLY IN GREAT BRITAIN AND NORTHERN IRELAND.



# ***Foreword***

**M**AZDA Lamps are made in England by the world-famous British Thomson-Houston Company, and are backed by more than half-a-century of experience in the manufacture of electric lamps.

Each lamp is designed with meticulous care by BTH Engineers and is constructed to the most precise tolerances from the finest available materials.

Not every Mazda Lamp, however, can be included in this catalogue; should your own special requirements for certain non-standard lamps not be fully satisfied, please consult any BTH Office.

# Clear Lamps

SINGLE COIL AND COILED COIL FILAMENTS



**Mazda**  
lamps  
stay brighter longer

## CLEAR G. L. S. LAMPS

Watts	Voltage and List Prices †									
	200, 210, 220, 230, 240, 250, 260		100, 110, 120, 130		60, 65, 75		35, 50, 55		25	
	s.	d.	s.	d.	s.	d.	s.	d.	s.	d.
<b>SINGLE COIL</b>										
15	1	6½†	1	6½†	1	11†	1	11	1	11
25	1	6½†	1	6½†	1	11	1	11	1	11
40	1	4½	1	6½	2	3	2	3	2	3
60	1	4½	1	6½	2	3	2	3	2	3
75	1	10	2	0	—	—	—	—	—	—
100	1	10	2	0	4	0	4	0	4	0
150	2	7	2	9	6	0	6	0	—	—
200	3	9	4	3	9	0	9	0	—	—
300§	7	6	8	0	12	0	12	0	—	—
500§	10	0	10	6	16	0	16	0	—	—
750§	16	0	16	0	—	—	—	—	—	—
1000§	17	6	17	6	—	—	—	—	—	—
1500§	25	0	25	0	—	—	—	—	—	—
<b>COILED COIL</b>										
40	1	9	—	—	—	—	—	—	—	—
60	1	9	—	—	—	—	—	—	—	—
75	2	1½	—	—	—	—	—	—	—	—
100	2	1½	—	—	—	—	—	—	—	—

† Purchase Tax must be added to the prices in these columns for lamps up to 250 watts. For the exact amount of purchase tax to be added, see TABLE A on the extension of page 55.

§ Lamps over 250 watts are exempt from purchase tax.

‡ These lamps are vacuum only, all other lamps on this page are gasfilled.

## Caps and Dimensions

Watts	Cap ‡	Approximate Dimensions †					
		Diameter		Length		Light Centre Length ‡	
		In.	m/m	In.	m/m	In.	m/m
15	B.C. (B22/25 × 26)	2-17	55	3-63	92-5	2-56	65
25		2-36	60	3-94	100	2-76	70
40		2-36	60	4-33	110	3-15	80
60		2-36	60	4-33	110	3-15	80
75		2-76	70	4-92	125	3-54	90
100	E.S. (E27/25)	2-95	75	5-39	137-5	3-94	100
150		3-15	80	6-30	160	4-72	120
200		3-54	90	7-00	178	5-24	133
300	G.E.S. (E40/45)	4-33	110	9-17	233	7-00	178
500		5-12	130	10-51	267	7-95	202
750		5-91	150	11-81	300	8-86	225
1000		5-91	150	11-81	300	8-86	225
1500		6-69	170	13-19	335	9-84	250

‡ Cap Illustrations will be found on pages 42 and 43.

† Lamp Outlines are shown on pages 40 and 41.

‡ Light Output of these lamps is given on page 44.

NOTE.—As an additional safety device, many Mazda lamps incorporate cartridge fuses.



100 watt CLEAR  
(with internal fuses)

# PEARL G. L. S. LAMPS

Watts	Voltages and List Prices *									
	200, 210, 220, 230, 240, 250, 260		100, 110, 120, 130		60, 65, 75		35, 50, 55		25	
	s.	d.	s.	d.	s.	d.	s.	d.	s.	d.
<b>SINGLE COIL</b>										
15	1	6½†	1	6½†	1	11†	1	11	1	11
25	1	6½†	1	6½	1	11	1	11	1	11
40	1	4½	1	6½	2	3	2	3	2	3
60	1	4½	1	6½	2	3	2	3	2	3
75	1	10	2	0	—	—	—	—	—	—
100	1	10	2	0	4	0	4	0	4	0
150	2	7	2	9	—	—	—	—	—	—
200	4	3	4	9	—	—	—	—	—	—
<b>COILED COIL</b>										
40	1	9	—	—	—	—	—	—	—	—
60	1	9	—	—	—	—	—	—	—	—
75	2	1½	—	—	—	—	—	—	—	—
100	2	1½	—	—	—	—	—	—	—	—

\* Purchase Tax must be added to the prices in these columns. For the exact amount of purchase tax to be added, see TABLE A on the extension of page 55.  
 † These lamps are vacuum only, all other lamps on this page are gasfilled.

## Caps and Dimensions

Caps and Dimensions of Pearl Lamps are the same as the equivalent wattage Clear Lamps; see list on opposite page.

### MAZDA CLEAR LAMPS (Opposite page)

A choice of either clear or pearl lamps is offered in wattages up to and including 200 watts. Higher wattages are available only with clear glass bulbs. The majority of both clear and pearl lamps are filled with an inert gas which permits the filament to be operated at a higher temperature and consequently at a higher efficiency than is possible with a vacuum lamp. As will be seen from the tables, in certain wattages lamps are also available with coiled coil filaments.

### MAZDA PEARL LAMPS

The inside frosting of the Mazda Pearl Lamp diffuses the light and reduces glare, while the amount of light absorbed by the frosting is negligible. Lamps with coiled coil filaments are also available in the wattages shown.

NOTE.—As an additional safety device, many Mazda lamps incorporate cartridge fuses.

# Pearl Lamps

SINGLE COIL AND  
COILED COIL  
FILAMENTS



**Mazda**  
lamps  
stay brighter longer



100 watt PEARL

# Silverlight Lamps

SINGLE COIL AND  
COILED COIL  
FILAMENTS



**Mazda**  
lamps  
stay brighter longer



100w SILVERLIGHT

## SILVERLIGHT G. L. S. LAMPS (Patents applied for)

Watts	Voltages	Cap ‡	List # Price s. d.	Dimensions †			
				Diameter		Length	
				In.	m/m	In.	m/m
<b>SINGLE COIL</b>							
40	200, 210, 220, 230, 240, 250, 260	B.C. (B22/25×26)  E.S. (E27/25)	1 7½	2-36	60	4-33	110
60			1 7½	2-36	60	4-33	110
100			2 1	2-95	75	5-39	137-5
150			3 1	3-15	80	6-30	160
200			4 9	3-54	90	7-00	178
<b>COILED COIL</b>							
40	200, 210, 220, 230, 240, 250, 260	B.C. (B22/25×26)	2 0	2-36	60	4-33	110
60			2 0	2-36	60	4-33	110
100			2 4½	2-95	75	5-39	137-5

\* Purchase Tax must be added to the prices in this column. For the exact amount of purchase tax to be added, see TABLE A on the extension of page 55.

‡ Cap Illustrations will be found on pages 42 and 43.

† Lamp Outlines are shown on pages 40 and 41.

Mazda Silverlight GLS Lamps are particularly attractive in all fittings in which the lamp is not completely hidden from view by some form of shade or reflector. They are recommended for use in floor standards and table lamps, and for all close and continuous work. The inside of the bulb is coated with very finely-divided silica which adheres so well to the bulb surface that the lamp will withstand all normal handling. The bright spot, so dazzling in a clear lamp and still present, though to a much lesser degree, in the pearl lamp has been smoothed away and, instead, the whole surface of the bulb glows with a beautifully soft, even brightness. As with ordinary G.L.S. lamps the coiled coil lamp gives up to 20% more light than its single coil equivalent.

*NOTE.*—As an additional safety device, all Mazda Silverlight lamps incorporate cartridge fuses.



200w  
SILVERLIGHT

## REFLECTOR SPOTLIGHT (Light Diffused Frosted)

Watts	Volts	List Price* s. d.		Cap	Dimensions			
					Length		Diameter	
					In.	m/m	In.	m/m
75	110, 200, 210, 220, 230, 240, 250	8	0	E.S.(E27/25) or B.C.(B22/25×26)	5.09	129±3	3.75	95±1

## REFLECTOR SPOTLIGHT (Light Diffused Frosted)

Watts	Volts	List Price* s. d.		Cap	Dimensions			
					Length		Diameter	
					In.	m/m	In.	m/m
150	110, 210, 230, 240, 250	15	6	E.S. (E27/57×38)	6.93	176±6.5	4.96	126±1.5

## REFLECTOR FLOODLIGHT (Pearl)

Watts	Volts	List Price* s. d.		Cap	Dimensions			
					Length		Diameter	
					In.	m/m	In.	m/m
150	110, 210, 230, 240, 250	15	6	E.S. (E27/57×38)	6.93	176±6.5	4.96	126±1.5

\* Purchase Tax must be added to the prices in these columns. For the exact amount of purchase tax to be added, see TABLE A on the extension of page 55.

## REFLECTOR LAMPS

These lamps are parabolic in shape and have the upper part coated on the inside with aluminium to form a highly efficient internal reflector which enables the light output to be used with maximum effect.

### REFLECTOR SPOTLIGHT

The bulbs of these lamps are light diffused frosted and the combination of filament and internal reflector ensures that the majority of the light output is concentrated into a narrow beam. The 75-watt lamp is available with a standard bayonet cap to fit the normal household lampholder. This lamp has many uses in the home, on the workbench, in shops or for displays.

### REFLECTOR FLOODLIGHT

The Reflector Floodlight differs from the Reflector Spotlight in having a pearl finish. This spreads the beam so that the light can be projected on to comparatively large areas, such as hoardings, exhibition displays, school chalk-boards etc.

150 watt

75 watt

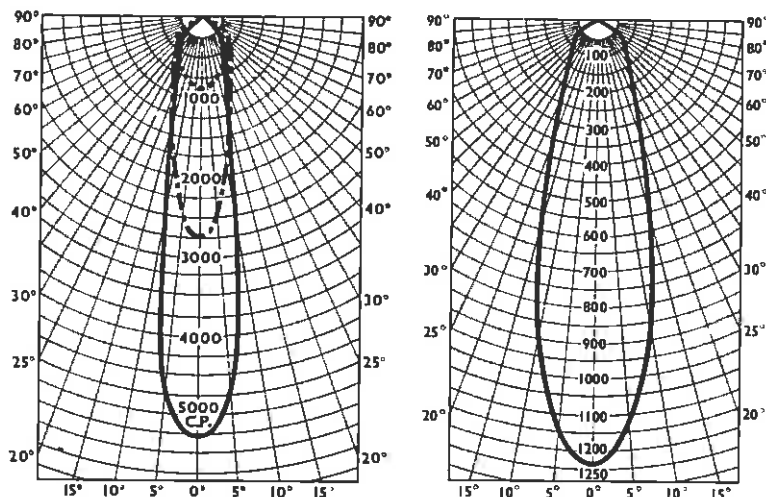

Polar Diagram (Candle power)

— Grid Filament Spotlight    - - - Ring Filament Spotlight    - - - Floodlight

# Reflector Lamps

SPOTLIGHT  
AND  
FLOODLIGHT



**Mazda**  
lamps  
stay brighter longer



75w  
REFLECTOR  
SPOTLIGHT  
LAMP

# Fluorescent Lamps

TYPE MCF/U  
FOR GENERAL  
LIGHTING



**Mazda**  
lamps

stay brighter longer

## STANDARD RANGE

Watts	Nominal Length	Colours Available	List Price †			
			Ordinary MCF/U		Instant Start MCFA/U	
			s.	d.	s.	d.
15	1½ ft.	Natural, Warm-White, Mellow	9	9	—	
20	2 ft.	Natural, Warm-White, Mellow	10	6	11	6
30	3 ft.	Natural, Warm-White, Mellow	11	0	12	0
40	2 ft.	Natural, Warm-White, Mellow	11	0	12	0
40	4 ft.	Natural, Warm-White, Mellow, Daylight or Colour Matching	11	9	12	9
80	5 ft.	Natural, Warm-White, Mellow, Daylight or Colour Matching, Red, Blue, Green, Yellow	13	0	14	0
			17	6	18	6

## 8 ft. FLUORESCENT LAMPS

Watts Determined by Auxiliary Gear	Nominal Length	Colours Available	List Price	
			s.	d.
50 or 70	8 ft.	Natural	30	0*
125	8 ft.	Natural	32	6

\* Purchase Tax must be added to these prices. For the exact amount of purchase tax to be added see TABLE A on the extension of page 55.

## CAPS AND DIMENSIONS

Watts	Nominal Length	Cap ‡	Dimensions			
			Overall Length		Diameter	
			In.	m/m	In.	m/m
15	1½ ft.	Med. Bi-pin 23(G2-4 × 13/23 × 10)	17 <sup>25</sup> / <sub>32</sub>	451	1	26
20	2 ft.	Med. Bi-pin 35(G2-4 × 13/35 × 10)	23 <sup>25</sup> / <sub>32</sub>	604	1½	38
30	3 ft.	Med. Bi-pin 23(G2-4 × 13/23 × 10)	35 <sup>25</sup> / <sub>32</sub>	909	1	26
40	2 ft.	Med. Bi-pin 35(G2-4 × 13/35 × 10)	23 <sup>25</sup> / <sub>32</sub>	604	1½	38
40 †	4 ft.	B.C. (B22/25 × 26)	47 <sup>25</sup> / <sub>32</sub>	1214	1½	38
80 †	5 ft.		60	1524	1½	38
50 or 70	8 ft.	Raised Contact (S24s/17)	93 <sup>7</sup> / <sub>8</sub>	2384	1	26
125	8 ft.	B.C. (B22/25 × 26)	96	2438	1½	38

‡ Cap illustrations will be found on pages 42 and 43.

Light Output of these lamps is given on page 44.

† Lamp Outlines are shown on pages 40 and 41.

Details of some of the Auxiliary Gear for use with these lamps are given on pages 46 and 47.

IMPORTANT NOTICE.—Mazda Electric Discharge Lamps are made to operate on standard supply voltages with appropriate Lamp Auxiliary Gear.

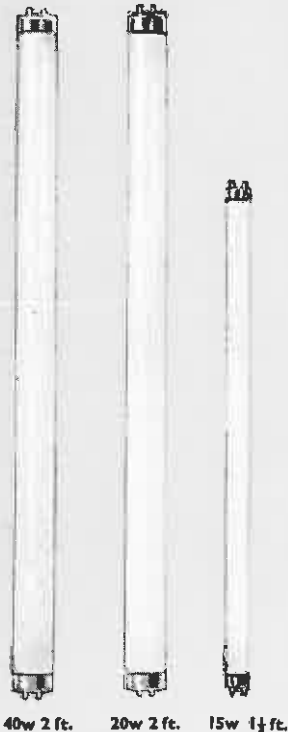

## TUNGSTEN BALLAST LAMPS

For use with 40 w. 4 ft. Fluorescent Lamps Type MCFA/U

Recent experience has revealed a need, in certain instances, for mixed fluorescent and tungsten lighting. One way of meeting this demand is to utilize a fluorescent lamp circuit in which the conventional choke is replaced by a special tungsten ballast lamp which not only serves to regulate the current but also emits useful light.

Main Voltage	Lamp Rating		Cap	Overall Dimens.		List Price s. d.
	Volts	Watts		Diam. m/m	Length m/m	
200/210	115	50	3-pin B.C. (B22/25 × 26)	65	117.5	2 6
220/230	140	60				
240	151	65				
250	162	70				

\* Purchase Tax must be added to the price of this lamp. For the exact amount of purchase tax to be added see TABLE A on the extension of page 55.

**FLUORESCENT LAMPS.** These lamps are designed to give all round satisfaction because BTH with their long experience of lamp manufacture realize that not one but many factors must be taken into account when assessing fluorescent lamp quality. Among these factors are :—

Initial light output	Maintenance of light output
Total watts consumed	Dependability
Uniformity	Colour
Price	Life

Regular and exhaustive life-tests prove beyond doubt that no fluorescent lamp on the market lasts longer than a Mazda. Further tests, based on the first 5000 hours of lamp life, show clearly that no other fluorescent lamp is more efficient.

*Mazda Low Pressure Fluorescent Lamps are made under one or more of the following British Patents : 469732, 480356, 520759, 521110, 523528, 530531, 533451, 535897, 537901, 563185, 578192, 580363, 610025, 578195, and other patents granted or pending.*

## THE MAZDA FLUORESCENT CIRCLE

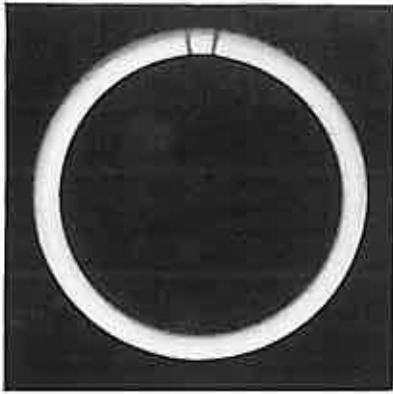

This circular fluorescent lamp is suitable for use in shops, restaurants, hotels or similar places where attractive appearance and adequate illumination are essential. It is also a very useful lamp for sign or display work. The gap between the ends of the lamp is filled by means of a special 4-pin cap, so completing the circular appearance.

The lamp is rated at 40 watts and uses ordinary switch start auxiliary gear as used for the 40 w. 4 ft. straight lamps.

Lamp Watts	Colour	Dimensions in m/m		List Price*	
		Outside Diameter of Circle	Outside Diameter of Tube	s.	d.
40	Mellow	403 ± 8	32 ± 2	35	0

\* Purchase Tax must be added to the price of this lamp. For the exact amount of purchase tax to be added, see TABLE A on the extension of page 55.

## STANDARD† COLD-CATHODE LAMPS *(Requiring high-voltage control-gear for operation)*

Colours Available	List Price (Purchase Tax not chargeable)		Dimensions					
			Overall Length		Ltc Length		Diameter	
			in.	m/m	in.	m/m	in.	m/m
Daylight Mellow Warm-White Natural Intermediate Gold	36	6	114	2896	102	2591	¾ appx.	20
Colour-matching								

† Cold-cathode lamps can also be supplied in non-standard lengths and in a variety of colours. Prices on application.



30w 3 ft.      40w 4 ft.      80w 5 ft.

# Light Tubes

ARCHITECTURAL SERIES



**Mazda**  
lamps  
stay brighter longer

## LIGHT TUBES

Watts	Nominal Length In.	Voltages and List Prices*				Dimensions †		
		200, 230, 260 w.	210, 240, 250, d.	100, 120, s.	110, 130, d.	Overall Length m/m	Diameter m/m	Distances between Round-Peg Side-Caps m/m
<b>STRAIGHT LENGTHS (White Opal †)</b>								
35	12	12	4	12	4	305	30	229
75	24	22	6	22	6	610	30	534
110	36	30	0	—	—	915	30	839
150	48	35	0	—	—	1220	30	1144
<b>CURVES—<math>\frac{1}{8}</math>, <math>\frac{1}{4}</math>, or <math>\frac{1}{2}</math> CIRCLES (White Opal †)</b>								
60	20	30	0	30	0	500§	30	$\frac{1}{8}$ Circle 416 $\frac{1}{4}$ " 393 $\frac{1}{2}$ " 309

\* Purchase Tax must be added to the prices in these columns. For the exact amount of purchase tax to be added, see TABLE A on the extension of page 55.

† Colour Spraying 10% extra for Red, Blue, Green, Yellow, Flame, Orange, Pink, or Amber.

‡ Lamp Outlines are shown on page 40.

§ Centre line of the curve.

### MAZDA LIGHT TUBES (Architectural Series)

These lamps, both the straight and curved variety, provide delightful lighting effects in the home, their appearance being that of a simple bar of light. They are particularly useful for installing above or on either side of wall mirrors and they can also be used for emphasizing architectural features. They can be used very effectively for display lighting in shops and stores, particularly in show-cases where their very neat appearance is an asset since it does not obtrude itself. The curved lamps are extensively used for decorative lighting in hotels, restaurants etc., and also for outlining advertising signs.



### LAMP HOLDERS

Special lampholders, as illustrated, are required for use with Light Tubes.

List Price

6s. 6d. per pair

Purchase Tax not chargeable.

Colour sprayed 8d. extra



12" STRAIGHT



## TUBULAR (CLEAR)

Watts	Voltages and List Prices †				Cap ‡	Approximate Dimensions †		
	200, 210, 220, 230, 240, 250, 260		110, 120	60, 65, 75		50	Diam. m/m	Length m/m
	s.	d.	s.	d.		s.		
<b>Single Cap (Vacuum)</b>								
10	—		3 9	4 9	4 9	} B.C. (B22/22) S.B.C. (BA.15d/17)	25	63
25	3 9	3 9	3 9	4 9	4 9		} B.C. (B22/22) S.B.C. (B15/24×17) S.E.S. (E14/27×18)	25
						25		86
						25		92
							25	94
<b>Double Cap (Vacuum)</b>								
30	5 9	5 9	—	—	} C.C. (S 15s)	}	25	221 or 284
60	6 0	6 0	—	—			25	

30w and 60w Tubular Lamps are available Frosted, Varnished or Sprayed In Standard Colours. 4d. each extra.

## CANDLE (PLAIN AND TWISTED)

Watts	Voltages and List Prices †				Cap ‡	Approximate Dimensions †		
	200, 210, 220, 230, 240, 250, 260		100, 110, 120, 130	60, 65, 75		25, 50	Diam. m/m	Length m/m
	s.	d.	s.	d.		s.		
<b>Plain</b>								
25a	3 9	3 9	4 9	4 9	} B.C. (B22/25×26) S.B.C. (B15/26×22) S.E.S. (E14/27×18) E.S. (E27/25)	39 max.	119	
40b	4 3	4 3	5 3	5 3		39 max.	122	
						39 max.	125	
						39 max.	119	
60b	4 9	4 9	5 9	5 9	} B.C. (B22/25×26) S.B.C. (B15/26×22) S.E.S. (E14/27×18) E.S. (E27/25)	47 max.	130	
						47 max.	133	
						47 max.	136	
						47 max.	130	
<b>Twisted</b>								
25a	4 3	4 3	5 3	5 3	} B.C. (B22/25×26) S.B.C. (B15/26×22) S.E.S. (E14/27×18) E.S. (E27/25)	39 max.	119	
40b	5 0	5 0	6 0	6 0		39 max.	122	
						39 max.	125	
						39 max.	119	
60b	5 6	5 6	6 6	6 6	} B.C. (B22/25×26) S.B.C. (B15/26×22) S.E.S. (E14/27×18) E.S. (E27/25)	57 max.	147	
						57 max.	150	
						57 max.	153	
						57 max.	147	

Candle Lamps sprayed in standard colours (page 26) (a) 2d. each extra (b) 3d. each extra.

## LONGLITE (OPAL)

Watts	Voltages and List Prices †		Cap ‡	Approx. Dimensions †		
	200, 210, 220, 230, 240, 250, 260			110, 120	Diam. m/m	Length m/m
	s.	d.		s.		
40 60	8 6	8 6	B.C. (B22/25×26) or E.S. (E27/25)	38	302	

† Purchase Tax must be added to the prices in these columns. For the exact amount of purchase tax to be added, see TABLE A on the extension of page 55.

‡ Cap Illustrations will be found on pages 42 and 43.

§ Lamp outlines are shown on pages 40 and 41.



DOUBLE CAP TUBULAR

# Tubular Candle and Longlite Lamps

FOR DECORATIVE  
LIGHTING



**Mazda**  
lamps  
stay brighter longer

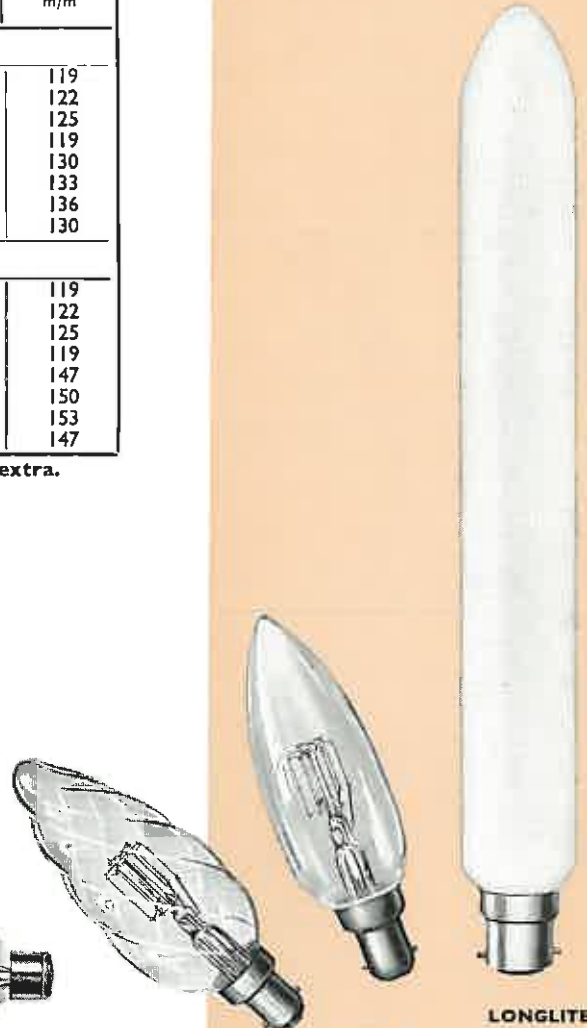

CANDLE  
(TWISTED & PLAIN)

LONGLITE

# Photographic Lamps

PHOTO FLOOD  
PHOTO PEARL  
PHOTO ENLARGER  
PHOTO COLOUR



**Mazda**  
lamps  
stay brighter longer

## PHOTOGRAPHIC LAMPS

Watts	Voltages	List Price s. d.	Cap §	Approximate Dimensions				Objective Life † Hours
				Overall Length		Diameter		
				m/m	in.	m/m	in.	
<b>PHOTO-FLOOD (Pearl)</b>								
275	{ 100/110, 200/210 220/230, 240/250 }	2 6	{ B.C. (B22/25 × 26) E.S. (E27/25) }	110	4-33	60	2-36	2
500	{ 100/110, 200/210 220/230, 240/250 }	6 6	{ E.S. (E27/25) E.S. (E27/35 × 30) B.C. (B22/25 × 26) ¶ }	160	6-30	80	3-15	10
1000	110	16 6	G.E.S. (E40/45) ...	233	9-17	110	4-33	10
<b>PHOTOGRAPHIC PEARL</b>								
500	110, 210, 230, 250	22 0	E.S. (E27/25) ...	178	7-0	90	3-54	100
<b>PHOTOGRAPHIC ENLARGER (Inside Silica-coated)</b>								
150	110, 210, 230, 240, 250	3 9½	{ B.C. (B22/25 × 26) E.S. (E27/25) }	117-5	4-61	65	2-56	100
<b>PHOTOGRAPHIC ENLARGER (2 in. Spot Frosted)</b>								
400	110, 210, 230, 250	27 6	E.S. (E27/45 × 38) ...	253	9-96	110	4-33	100

\* Purchase Tax must be added to the price of this lamp. For the exact amount of purchase tax to be added see TABLE A on the extension of page 55.  
† Light Output of these lamps is given on page 44. ¶ Not available for 100/110 volt.  
§ Cap Illustrations will be found on pages 42 and 43.

## LAMPS FOR COLOUR PHOTOGRAPHY

Watts	Volts	List Price s. d.	Colour Temp.	Cap	Approx. Dimensions				Objective Life Hours
					Length		Diameter		
					m/m	in.	m/m	in.	
275	230	3 0	3200°K	{ E27/25 or E27/35 × 30 }	117-5	4-63	65	2-56	10
500	230	7 6	3200°K		160	6-30	80	3-15	10
500	230	31 6	3200°K	P28/25	133 ± 7	5-24	64 ± 2	2-52	10
500	115	31 6	3350°K	P28/25	133 ± 7	5-24	64 ± 2	2-52	10

### PHOTO-FLOOD and PHOTO-PEARL

These lamps are for use on normal lighting circuits and provide a ready means of obtaining a large amount of light of high photographic efficiency for a low current consumption. They are invaluable to the home photographer and cinematographer, and greatly facilitate the operations of commercial photographers both inside and outside the studio.

### PHOTO-ENLARGER (Inside Silica-coated)

The Mazda Photo-enlarger Lamp is a high intensity 150-watt lamp, internally silica-coated and concentrated into a 60-watt size bulb with a B.C. or E.S. cap. It is highly efficient, with a 100 hours life. The internal silica coating gives an even distribution of vivid light over the whole bulb and the completely smooth exterior is easily kept clean.



PHOTO PEARL

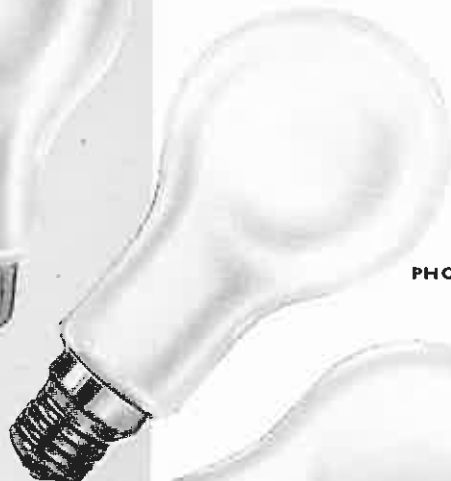

PHOTO FLOOD



PHOTO ENLARGER  
(Inside Silica-coated)

# FLASH DISCHARGE TUBES

Type	Operating Voltage	List Price (Purchase Tax not chargeable)	Cap	Dimensions m/m		
				Length (excluding pins)	Diameter of Glass	L.C.L.
FA 1	2000—2700	£ 6 0 0	3-pin Special	150±7	64±4	89±5
FA 2	2000—2700	5 0 0	3-pin 5 amp.	90±5	46±2	55±5
FA 2S	2000—2700	5 0 0	3-pin 5 amp.	90±5	46±2	55±5
FA 3	2000—2700	5 0 0	U.X. 4-pin	80±2	31±2	48±5
FA 4	2000—2700	3 18 6	Flexible leads		Circular	
FA 5	1000—2000	10 10 0	0.359" dia. ferrules	148±4	32 Max.	Arc Gap 4.5-5.5
FA 6	500—1100	4 10 0	U.X. 4-pin	70±2	31±2	42±3
FA 7	2000—2700	5 0 0	U.X. 4-pin	80±2	31±2	48±5
FA 8	250—500	5 0 0	International Octal	55±2	25±1	34±3
FA 9	500—1100	5 0 0	U.X. 4-pin	80±2	31±2	48±3

## CHARACTERISTICS

Type	Volts	Mfd. Capacity at Max. Voltage	Rate of Flashing per sec.	Energy per flash W. sec.
FA 1	2000—2700	320	1 in 10 sec.	1000
FA 2	2000—2700	160	1 in 10 sec.	500
FA 2S	2000—2700	—	300 per sec.	—
FA 3	2000—2700	32	1 in 10 sec.	100
FA 4	2000—2700	96	1 in 10 sec.	300
FA 5	1000—2000	—	1 in 10 sec.	150
FA 6	500—1100	200	1 in 10 sec.	100
FA 7	2000—2700	64	1 in 10 sec.	100—200
FA 8	250—500	600	1 in 10 sec.	75
FA 9	500—1100	400	1 in 10 sec.	200

The ratings shown in this table are conservative and should be taken as a guide only.

Both the "No. 5" and "SM" are designed to give adequate light for general indoor photography. Their bulbs are lacquered both internally and externally, but it is recommended that they should be used in conjunction with a simple transparent protective screen.

"No. 5". This lamp is filled with shredded aluminium foil and is designed to operate with conventional synchronisms adjusted so that the camera shutter is fully opened in 21 milliseconds which is the time taken for the lamp to reach peak intensity.

"Speed Midget". The combustible material used in the "SM" lamp consists of zirconium mixed with oxidizing agents. It can be used with a simple pair of contacts which are closed immediately the blade or compur type shutter is released, thus synchronizing with the peak intensity which occurs after 7 milliseconds.

"No. 22". Like the "No. 5", this bulb has a filling of thin aluminium foil. It is larger than the others and is designed primarily for outdoor work or for use in very spacious halls. The "No. 22" is convenient and reliable when used with a camera fitted with a synchronizer.

Mazda Flash Discharge Tubes are intended to produce a flash of light of high intensity and short duration for either photographic or stroboscopic applications. The intensity of the flash and its duration may be controlled by varying the values of the components in the electrical circuit. The tubes may be flashed repeatedly for many thousands of times to give single flashes with relatively long intervening intervals for photographic purposes. Types FA 1 and FA 2 can also be flashed at a rate of up to some hundreds of flashes per second for stroboscopic applications. The mean power dissipation is 80 watts and 40 watts respectively.

## PHOTOFLASH LAMPS

Type	Volts*	List Price (Purchase Tax not chargeable)		Cap	Overall Dimens. m/m	
		s.	d.		Length	Diam.
No. 5	3-9	1	1	S.C.C. (BA.15s/21) E.S.	64	34
S.M.		1	3			
No. 22		1	8			

\* These lamps are designed to operate from a 3-9 volts dry battery. Two fresh dry cells in series will flash many lamps.

# Photographic Lamps

## FLASH DISCHARGE TUBES AND PHOTOFLASH LAMPS



**Mazda**  
lamps  
stay brighter longer



No. 22



FA 6

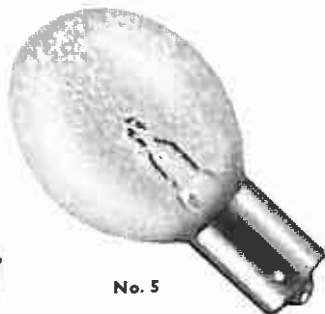

No. 5



"S.M."

# Projector Lamps

## CLASS A I



**Mazda**  
lamps  
stay brighter longer

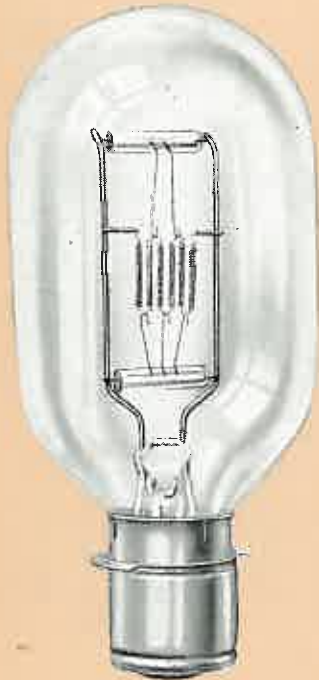

115v 500w  
PREFOCUS  
(A1/8)



← 230v 300w  
PREFOCUS  
(A1/154)



← 30v 100w  
PREFOCUS  
(A1/3)



← 100v 200w  
S.C.C.  
(A1/26)

## CLASS A I (Purchase Tax not chargeable) Burning Position—Cap-down (except where indicated)

Lamp Ref. No.	Watts	Voltages	List Price s. d.	Cap	Approx. Dimensions m/m			Special Features	Objective Life Hours
					Length	Diam.	L.C.L.		
A1/ 72	10	20	4 9	S10/20 x 13, Pathé T Piece	57 ± 3	15 ± 1	25 ± 0.5	—	100
A1/ 73	15	40	4 0	S.C.C. (BA.15s/21)	57 ± 3	16 ± 1	29 ± 2	—	50
A1/ 1	25	50	4 9	S.C.C. (BA.15s/21)	57 ± 3	16 ± 1	29 ± 2	—	50
A1/ 2	50	100, 110, 115	7 3	S.C.C. (BA.15s/21)	76 ± 3	25 ± 1	34.5 ± 2	—	50
A1/ 19	50	100, 110, 115	7 3	S.B.C. (B15d)	76 ± 3	25 ± 1	34.5 ± 2	—	50
A1/ 21	100	100, 110, 115	12 9	S.C.C. (BA.15s)	76 ± 5	25 ± 1	34.5 ± 2	—	50
A1/ 23	100	12	11 9	E.S. (E27/25)	128 ± 7	25 ± 1	75 ± 5	—	50
A1/ 4	100	12	12 9	Prefocus (P28/25)	133 ± 7	25 ± 1	55.5 ± 0.5	—	50
A1/135	100	24	13 9	S.B.C. (B15d/21)	75 ± 3	25 ± 1	55 ± 2	Transverse C.C.	100
A1/ 3	100	30	12 9	Prefocus (P28/25)	133 ± 7	25 ± 1	55.5 ± 0.5	Offset Fil.	50
A1/121	100	100, 110, 115	12 9	S.B.C. (B15d)	76 ± 3	25 ± 1	34.5 ± 2	—	50
A1/ 4	100	200-10-20-30-40-250	12 9	Prefocus (P28/25)	133 ± 7	25 ± 1	55.5 ± 0.5	—	50
A1/ 23	100	200-10-20-30-40-250	11 9	E.S. (E27/25)	128 ± 7	25 ± 1	75 ± 5	—	50
A1/151	200	50	23 0	S.C.C. (BA.15s)	87 ± 5	25 ± 1	34.5 ± 2	Grid Fil.	50
A1/ 12	200	50	23 0	E.S. (E27/25)	128 ± 7	32 ± 2	75 ± 5	Central Fil.	50
A1/112	200	50	23 0	E.S. (E27/25)	128 ± 7	32 ± 2	75 ± 5	Offset Fil.	50
A1/ 13	200	50	24 0	Prefocus (P28/25)	133 ± 7	32 ± 2	55.5 ± 0.5	Central Fil.	50
A1/113	200	50	24 0	Prefocus (P28/25)	133 ± 7	32 ± 2	55.5 ± 0.5	Offset Fil.	50
A1/ 80	200	100	26 0	3-pin B.C.	82 ± 3	32 ± 2	51 ± 0.5	Offset Fil. Cap-up Burning	25
A1/ 25	200	100	18 6	S.B.C. (BA.15d)	87 ± 5	25 ± 1	34.5 ± 2	—	25
A1/ 26	200	100	18 6	S.C.C. (BA.15s)	87 ± 5	25 ± 1	34.5 ± 2	—	25
A1/ 27	200	100, 110	19 6	Prefocus S.C.C. (P15s)	87 ± 5	25 ± 1	31.5 ± 0.5	—	25
A1/127	200	100, 110	19 6	Prefocus S.B.C. (P15d)	87 ± 5	25 ± 1	31.5 ± 0.5	—	25
A1/ 83	200	100, 115	18 6	S.B.C. (BA.15d)	87 ± 5	32 ± 1	34.5 ± 0.5	—	50
A1/ 81	200	110	19 6	Pathé T Piece	133 ± 7	32 ± 2	58 ± 0.5	Offset Fil.	50
A1/ 12	200	110	18 6	E.S. (E27/25)	128 ± 7	32 ± 2	75 ± 5	—	50
A1/ 13	200	110	19 6	Prefocus (P28/25)	133 ± 7	32 ± 2	55.5 ± 0.5	—	50
A1/ 85	250	50	24 0	Prefocus B & H (small)	128 ± 7	32 ± 2	59 ± 0.5	—	50
A1/ 14	250	50	23 0	E.S. (E27/25)	128 ± 7	32 ± 2	75 ± 5	Central Fil.	50
A1/ 16	250	50	23 0	E.S. (E27/25)	128 ± 7	32 ± 2	75 ± 5	Offset Fil.	50
A1/ 15	250	50	24 0	Prefocus (P28/25)	133 ± 7	32 ± 2	55.5 ± 0.5	Offset Fil.	50
A1/ 5	250	50	24 0	Prefocus (P28/25)	133 ± 7	32 ± 2	55.5 ± 0.5	Central Fil.	50
A1/ 5	250	55	24 0	Prefocus (P28/25)	133 ± 7	32 ± 2	55.5 ± 0.5	Central Fil.	50
A1/ 5	250	100, 110, 115 200-10-20-30-40-250	23 0	Prefocus (P28/25)	133 ± 7	32 ± 2	55.5 ± 0.5	Central Fil.	50
A1/ 14	250	100, 110, 115 200-10-20-30-40-250	22 0	E.S. (E27/25)	128 ± 7	32 ± 2	75 ± 5	—	50

For Notes see opposite page.

## CLASS A1 PROJECTOR LAMPS

Class A1 lamps have tubular bulbs and are used for cap-down burning in Cinema Projectors, Home Cinema Apparatus, Advertising Projectors, Photo-enlarging Apparatus, etc. They can be brought close to the lens and by use of a short focus condenser, an unusually large proportion of light can be transmitted. For the home cinema the introduction of the prefocus cap has reduced focusing difficulties to a minimum.

**CLASS A I** (Purchase Tax not chargeable) **Burning Position—Cap-down** (except where indicated)

Lamp Ref. No.	Watts	Voltages	List Price s. d.	Cap	Approx. Dimensions m/m			Special Features	Objective Life Hours
					Length	Diam.	L.C.L.		
A1/ 38	300§	100, 115	28 6	Prefocus S.C.C. (P15s)	100±5	25±1	31.5±0.5	—	25 S
A1/ 36	300§	100, 115	28 6	Prefocus S.B.C. (P15d)	100±5	25±1	31.5±0.5	—	25 S
A1/ 37	300§	100, 115	27 4	S.C.C. (BA.15s/21)	100±5	25±1	34.5±2	—	25 S
A1/ 33	300§	100, 115	27 4	S.B.C. (BA.15d/21)	100±5	25±1	34.5±2	—	25 S
A1/ 6	300§	100, 110, 115	28 6	Prefocus (P28/25)	133±7	32±2	55.5±0.5	—	25 S
A1/154	300	210, 230, 240, 250	28 6	Prefocus (P28/25)	133±7	32±2	55.5±0.5	—	25 S
A1/ 86	300§	100, 110, 115	35 0	S.26s/25 large B & H Ring	128±7	32±2	59 ±0.5	Bi-plane Fil.	25 S
A1/ 39	400§	100, 110, 115	35 0	Prefocus (P28/25)	133±7	32±2	55.5±0.5	Bi-plane Fil.	25 S
A1/ 87	400§	110	35 0	Prefocus B & H (small)	128±7	32±2	59 ±0.5	Bi-plane Fil.	25 S
A1/159	400§	110	35 0	Prefocus B & H (large)	128±7	32±2	59 ±0.5	Bi-plane Fil.	25 S
A1/ 88	450	15	44 0	Special 2-prong	195	79 30	136	Special Shape Bulb, Cap-up Burning	100
A1/ 42	500	100, 110, 115 200-10-20-30-40-250	26 6	E.S. (E27/25)	128±7	64±2	75 ±5	—	50
A1/ 8	500	100, 110, 115 200-10-20-30-40-250	27 6	Prefocus (P28/25)	133±7	64±2	55.5±0.5	—	50
A1/ 46	500§	110	37 0	3-pin B.C. (B22/25×26)	142 max.	38 max.	95	Bi-plane Fil. Offset, Cap-up Burning	25
A1/ 47	500§	110	37 0	Prefocus B & H (small)	128±7	32±2	59 ±0.5	Bi-plane Fil.	25 S
A1/160	500§	110	37 0	Prefocus B & H (large)	128±7	32±2	59 ±0.5	Bi-plane Fil.	25 S
A1/ 7	500§	110, 115	37 0	Prefocus (P28/25)	133±7	32±2	55.5±0.5	Bi-plane Fil.	25 S
A1/153	500§	110, 115	38 0	3-fin Ring	145±8	38 max.	81	Bi-plane, Central Fil.	25
A1/ 52	750§	110	43 6	3-fin Ring	145±8	38 max.	81	Bi-plane Fil. Offset, Cap-up Burning	25
A1/ 53	750§	110, 115	42 6	Prefocus B & H (large)	128±7	38±2	59 ±0.5	Bi-plane Fil.	25 S
A1/ 9	750§	110, 115	42 6	Prefocus (P28/25)	133±7	38±2	55.5±0.5	Bi-plane Fil.	25 S
A1/111	900	24, 30	38 6	G.E.S. (E40/45)	230±10	64±2	120 ±5	—	50
A1/ 10	900	30	41 0	Mogul Prefocus (P40/41)	235±10	64±2	84 ±0.5	—	50
A1/ 92	1000§	100	49 6	Prefocus B & H (large)	175	38±2	78	Bi-plane Fil.	25 S
A1/ 57	1000	100, 110, 115 200-10-20-30-40-250	33 0	G.E.S. (E40/45)	230±10	64±2	120 ±5	—	50
A1/ 11	1000	100, 110, 115 200-10-20-30-40-250	35 6	Mogul Prefocus (P40/41)	235±10	64±2	84 ±0.5	—	50
A1/ 59	1000§	110, 115	49 6	Prefocus (P28/25)	133±7	38±2	55.5±0.5	Bi-plane Fil.	25 S
A1/ 91	1000§	110, 115	49 6	Prefocus B & H (large)	128±7	38±2	59 ±0.5	Bi-plane Fil.	25 S
A1/ 58	1000§	110	49 6	Prefocus (P28/25)	133±7	64±2	55.5±0.5	Bi-plane Fil.	25

**NOTE:** If ordering by Lamp Reference Number please be sure to state voltage required. In the case of Bell & Howell Projector lamps, state also whether large or small prefocus ring is required.

§ Forced cooling is necessary for these lamps so that no part of the wall of the bulb exceeds a temperature of 500°C.

S. These lamps are black sprayed. Where bulbs are tip black sprayed, the 25 m/m diameter bulb is sprayed to 22.5±2.5 m/m from the centre of the filament to the edge of the black spray; in the case of the 32 and 38 m/m dia. bulbs to 27.5±2.5 m/m.

Cap illustrations will be found on pages 42 and 43.

# Projector Lamps

**CLASS A I**



**Mazda**  
lamps  
stay brighter longer

→  
115v 250w  
PREFOCUS  
(A1/5)



→  
110v 750w  
B & H CAP  
BI-PLANE FIL.  
(A1/53)

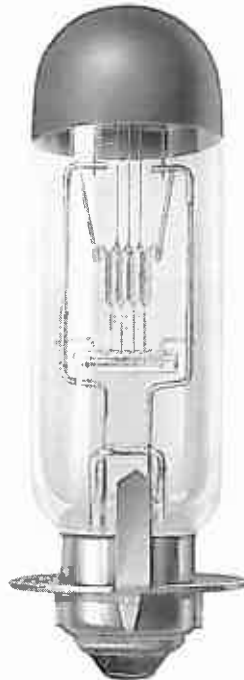

→  
110v 500w  
PREFOCUS  
BI-PLANE FIL.  
(A1/7)

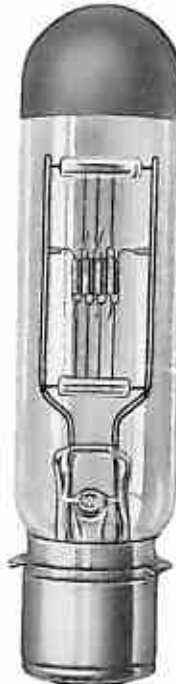

110v 1000w  
PREFOCUS  
BI-PLANE FIL.  
(A1/59)

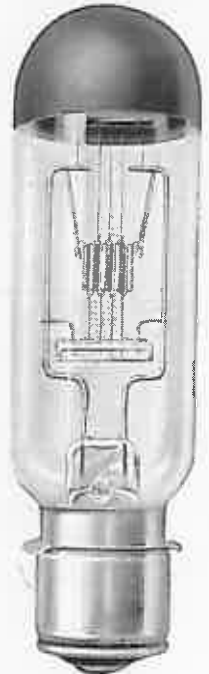

# Projector Lamps

CLASS B 1  
CLASS A 3



**Mazda**  
lamps  
stay brighter longer

## CLASS A3 and B1

Lamp Reference Number	Watts	Voltages	List Price s. d.	Cap §	Approx. Dimensions m/m			Objective Life Hours
					Length	Diameter	L.C.L.	
<b>CLASS A 3</b> <i>Burning Position—Horizontal</i>								
A3/1	100	{ 200-10-20-30-40-250 } <sup>110</sup>	11 9*	E.S. (E27/25) ...	115±10	70±2	95±5	300
A3/2	250	{ 200-10-20-30-40-250 } <sup>110</sup>	22 0*	E.S. (E27/35×30)	160±10	90±2	120±5	300
<b>CLASS B 1</b> <i>Burning Position—Any, except within 45° of Cap-up position</i>								
B1/1	100	{ 200-10-20-30-40-250 } <sup>115</sup>	10 0*	E.S. (E27/25) ...	115±10	80±2	75±5	800
B1/2	250	{ 200-10-20-30-40-250 } <sup>115</sup>	19 3*	E.S. (E27/25) ...	125±10	95±2	75±5	800
B1/3	500	{ 200-10-20-30-40-250 } <sup>115</sup>	25 3	G.E.S. (E40/45) ...	180±10	130±5	115±5	800
B1/4	1000	{ 200-10-20-30-40-250 } <sup>115</sup>	33 0	G.E.S. (E40/45) ...	180±10	130±5	115±5	800

\* Purchase Tax must be added to the list price of these lamps. For the exact amount of purchase tax to be added see TABLE A on the extension of page 55.

§ Cap Illustrations will be found on pages 42 and 43.

NOTE: If ordering by Lamp Reference Number please be sure to state voltage required.

### CLASS A 3 PROJECTOR LAMPS

Class A 3 lamps are used extensively for various stage lighting purposes in theatres and cinemas, and have also found wide application in Photographic and Film Studios.

They are intended for burning in a horizontal position, but slight variations of burning angle up to about 15° will not affect the life.

### CLASS B 1

Class B 1 lamps are made with concentrated bunch filaments of small area and are particularly suitable for use in conjunction with parabolic mirrors. They are employed generally for stage and theatre floodlighting and the floodlighting of tall buildings, hoardings, signs, etc., where long life and reliability are of chief importance.

Class B 1 lamps may be burned in any position except within 45° of Cap-up position.



CLASS B 1

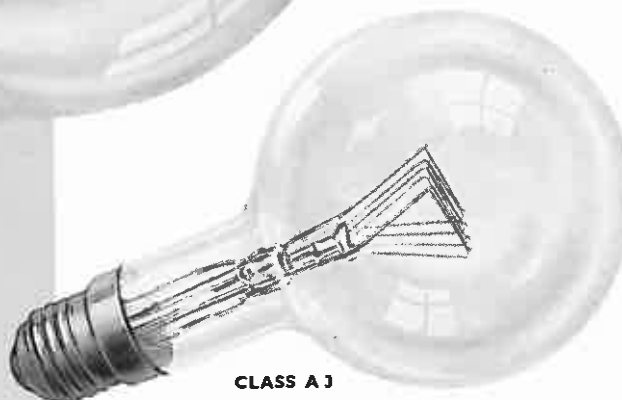

CLASS A 3

## CLASS E, EPIDIASCOPE *Burning Position—Any within 45° of Cap-down position*

Lamp Reference Number	Watts	Voltages	List Price s. d.	Cap §	Approx. Dimensions m/m			Objective Life Hours
					Length	Diameter	L.C.L.	
E/1	500	$\left. \begin{matrix} 115 \\ 200-10-20-30-40-250 \end{matrix} \right\}$	31 3	Prefocus (P28/25)	135±10	100±5	60 ±0.5	100
E/3	500	$\left. \begin{matrix} 110 \\ 200-10-20-30-40-250 \end{matrix} \right\}$	30 3	E.S. (E27/30) ....	135±10	100±5	85 ±5	100
E/4	500	$\left. \begin{matrix} 110 \\ 200-10-20-30-40-250 \end{matrix} \right\}$	31 3	Prefocus (P28/25)	130±10	95±5	55.5±0.5	100

† Purchase Tax not chargeable.

## CLASS F, MICRO-PROJECTION

Lamp Reference Number	Watts	Voltages	List Price s. d.	Special Features	Cap	Approximate Dimensions m/m			Objective Life Hours
						Length	Diam.	L.C.L.	
F 30	8	4	5 0	Transverse Filament	E.S. (E14/23 × 15)	62 ± 5	35 ± 2	52 ± 5	100
F 8	12	12	4 6	—	S.B.C. (B15d/24 × 17)	57 ± 5	37 max.	40 ± 3	100
F/24	24	6	4 0	—	E.S. (E27/25)	57 ± 5	38 ± 2	47 ± 5	100
F/10	24	6	4 0	—	S.E.S. (E14/23 × 15)	60 ± 5	38 ± 2	50 ± 5	100
F/ 3	24	12	4 0	Transverse Filament	S.B.C. (B15d/24 × 17)	60 ± 5	38 ± 2	44 ± 5	100
F 10	24	12	4 0	—	S.E.S. (E14/23 × 15)	60 ± 5	38 ± 2	50 ± 5	100
F 11	24	12	4 0	—	S.E.S. (E14/23 × 15)	60 ± 5	38 ± 2	41 ± 3	100
F/25	30	6	6 6	—	E.S. (E27/35 × 30)	63 ± 5	35 ± 2	53 ± 5	25
F/ 1	30	6	6 6	Transverse Filament	S.E.S. (E14/23 × 15)	57 ± 5	35 ± 2	47 ± 5	25
F/ 2	48	6	8 3	Transverse Filament	S.B.C. (B15d/24 × 17)	60 ± 5	35 ± 2	40 ± 3	100
F/52	48	6	8 3	Transverse Filament	E.S. (E14/27 × 18)	62 ± 3	35 ± 2	49 ± 2	100
F/ 4	48	12	6 0	Twin Pillar	S.E.S. (E14/23 × 15)	70 ± 5	50 ± 2	40 ± 3	100
F/13	48	12	6 0	—	E.S. (E27/25)	70 ± 5	50 ± 2	38 ± 5	100
F 42	48	12	6 0	—	Prefocus (P28/25)	75 ± 5	50 ± 2	18.5 ± 0.5	100
F 38	48	12	6 0	—	S.B.C. (B15d/24 × 17)	60 ± 5	38 ± 2	40 ± 3	100
F/27	72	6	11 9	Tubular Bulb	E.S. (E27/25)	128 ± 7	32 ± 1	75 ± 3	100
F/14	100	12	13 3	—	E.S. (E27/25)	85 ± 5	60 ± 2	55 ± 5	100
F/15	108	6	34 0	—	Prefocus (P28/25)	139 ± 7	32 ± 2	65 ± 0.5	50
F/16	(18 amp.) 108	6	33 0	Axial Ribbon Filaments	E.S. (E27/25)	135 ± 4	32 ± 2	86 ± 3	50
F/48	(18 amp.) 108	6	34 0		Prefocus (P28/25)	133 ± 7	32 ± 2	55.5 ± 0.5	50
F/49	(18 amp.) 108	6	33 0	Horizontal Ribbon Filaments	E.S. (E27/25)	128 ± 7	32 ± 2	75 ± 5	50
F/46	(18 amp.) 108	6	34 0		Prefocus (P28/25)	139 ± 7	32 ± 2	65 ± 0.5	50
F/47	(18 amp.) 108	6	33 0		E.S. (E27/25)	135 ± 4	32 ± 2	86 ± 3	50
F/50	(18 amp.) 108	6	34 0		Prefocus (P28/25)	133 ± 7	32 ± 2	55.5 ± 0.5	50
F/51	(18 amp.) 108	6	33 0	—	E.S. (E27/25)	128 ± 7	32 ± 2	75 ± 5	50

NOTE: If ordering by Lamp Reference Number please be sure to state voltage required.

\* Purchase Tax must be added to the prices in this column. For the exact amount of purchase tax to be added see TABLE A on the extension of page 55.

§ Cap Illustrations will be found on pages 42 and 43.

## CLASS E, EPIDIASCOPE

Class E lamps are used in episcopes and epidiscopes apparatus for the projection of lantern slides, small solid objects, picture book pages, etc. They are also suitable for spotlight and shop window projectors which have to be rotated through wide angles. Can be operated in any position up to 45° from vertical, cap downwards.

## CLASS F, MICRO-PROJECTION

Class F lamps have been specially designed to the requirements of micro-projection. Being of low voltage, they can be conveniently operated from batteries or from the mains through a suitable resistance or transformer. Microscope illumination, small home cine projectors, sound recording are but a few of the many purposes for which these lamps may be used.

# Projector Lamps

CLASS E, EPIDIASCOPE  
CLASS F,  
MICRO-PROJECTION



**Mazda**  
lamps  
stay brighter longer

E/1 EPIDIASCOPE



F/10 MICRO-PROJECTION

# Projector Lamps

## CLASS G AND TUBULAR FLOODLIGHT



**Mazda**  
lamps  
stay brighter longer

### CLASS G, EXCITER

Must not be burned cap-up

Lamp Reference Number	Amps.	Voltages	List Price† s. d.	Cap ‡	Approx. Dimensions m/m			Objective Life Hours
					Length	Diam.	L.C.L.	
G/ 1	0.75	4	7 0	Prefocus (P15s/19)	48±3	25±1	28.5 ±0.5	50
G/ 2	0.75	4	6 0	S.C.C. (BA.15s/21)	48±3	25±1	32 ±1.5	50
G/19	0.75	4	6 0	BA.15s and liner	48±3	15±1	31.75±0.75	50
G/29	0.75	4	7 0	Prefocus (P15s/19)	57±3	16±1	28.5 ±0.5	50
G/ 4	1.0	6	6 0	S.C.C. (BA.15s/17)	40±2	18±1	21.5 ±0.5	100
G/ 5	1.0	6	6 0	Prefocus (P15s/19)	57±3	16±1	28.5 ±0.5	100
G/16	1.0	27	9 0	S.C.C. (BA.15s/21)	75±3	25±1	41 ±1	100
G/ 6	2.0	8 (EL No. 4)	6 0	S.C.C. (BA.15s/21)	75±3	25±1	44 ±1	100
G/37	2.0	8	7 0	Prefocus (P15s/19)	75±3	25±1	37.3 ±0.5	100
G/ 8	4.0	8 (EL No. 2)	6 0	S.C.C. (BA.15s/21)	75±3	25±1	44 ±1	100
G/ 7	4.0	8	7 0	Prefocus (P15s/19)	75±3	25±1	37.3 ±0.5	100
G/ 9	4.0	8.5 (EL No. 3)	6 0	S.C.C. (BA.15s/21)	75±3	25±1	44 ±1	100
G/36	5.0	6	8 6	S.C.C. Pathe Collar	52±2	18±1	27 ±0.5	100
G/11	5.0	10 (EL No. 5)	8 0	S.C.C. (BA.15s/21)	75±3	25±1	41 ±1	100
G/10	5.0	10	9 0	Prefocus (P15s/19)	75±3	25±1	37.3 ±0.5	100
G/12	5.0	10 (EL No. 6)	8 0	S.C.C. (BA.15s/21)	75±3	25±1	44 ±1	100
G/22	6.0	4	6 6	S.C.C. (BA.15s/21)	49±3	25±1	31.5 ±1	100
G/23	6.5	5	8 0	Prefocus (P15s/19)	75±3	25±1	41 ±0.5	50
G/14	7.5	10 (EL No. 7)	8 0	S.C.C. (BA.15s/21)	75±3	25±1	41 ±1	100
G/13	7.5	10	9 0	Prefocus (P15s/19)	75±3	25±1	37.3 ±0.5	100
G/15	7.5	10 (EL No. 8)	8 0	S.C.C. (BA.15s/21)	75±3	25±1	44 ±1	100

### TUBULAR FLOODLIGHT

Burning Position—Horizontal

Lamp Reference Number	Watts	Voltages	List Price† s. d.	Cap ‡	Approx. Dimensions m/m		Objective Life Hours
					Length	Diameter	
FL/1	500	$\left\{ \begin{array}{c} 115 \\ 200-10-20-30-40-250 \end{array} \right\}$	38 6	G.E.S. (E40/45) ...	355±10	90±2	1000
FL/2	1000	$\left\{ \begin{array}{c} 115 \\ 200-10-20-30-40-250 \end{array} \right\}$	49 6	G.E.S. (E40/45) ....	390±10	90±2	1000

† Purchase Tax not chargeable.

‡ Cap illustrations will be found on pages 42 and 43.

NOTE:—If ordering by Lamp Reference Number please be sure to state voltage required.

### CLASS G EXCITER

For reproduction in sound film apparatus a low voltage lamp of high efficiency and robust construction is necessary. The Class G lamps listed here are ideal for this class of work and are manufactured with extreme accuracy and careful attention to such details as the centring of the filament and its luminous intensity so as to comply with the rigid requirements of sound film projection.



CLASS G, 4v  
0.75 amp.

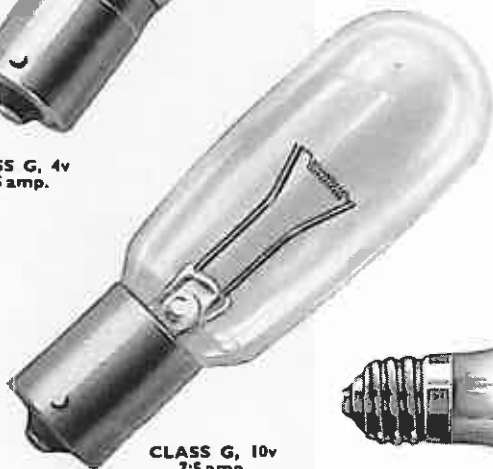

CLASS G, 10v  
7.5 amp.

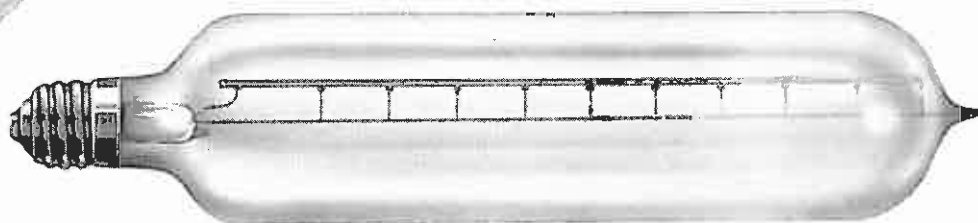

TUBULAR FLOODLIGHT



## STUDIO SPOTLIGHTS

Lamp Reference Number	Watts	Voltages	List Price†		Cap ‡	Approx. Dimensions m/m			Objective Life Hours
			s.	d.		Length	Diameter	L.C.L.	
S/4	1000	115, 210, 230, 240, 250	71	6	Bi-post ....	232±6	152.5±2	127±2	100
S/1	2000	115, 210, 230, 240, 250	93	6	Bi-post ....	232±6	152.5±2	127±2	100
S/2	5000	115, 230, 240, 250	300	0	Bi-post ....	335±6	203 ±2	165±2	100

† Purchase Tax not chargeable.

## “ BROADSIDE ”

Watts	Voltages	List Price†		Cap ‡	Approximate Dimensions m/m			Objective Life Hours
		s.	d.		Length	Diameter	L.C.L.	
1000	110, 115, 200, 210, 220, 230, 240, 250, 260	17	6	G.E.S. (E40/45) ....	300	150	225	1000
1500					335	170	250	1000

† Purchase Tax not chargeable.

## COLOUR TEMPERATURE 3400°K

Watts	Voltages	List Price†		Cap ‡	Approximate Dimensions m/m			Objective Life Hours
		s.	d.		Length	Diameter	L.C.L.	
2000	115	93	6	Bi-post ....	232±6	152.5±2	127±2	15
5000	115	300	0	Bi-post ....	335±6	203 ±2	165±2	25

† Purchase Tax not chargeable.

‡ Cap Illustrations will be found on pages 42 and 43. Details of Bi-post lampholders are given on page 45.

## HOSPITAL THEATRE DOUBLE FILAMENT PEARL LAMP

Filament	Watts	Voltages	List Price*†		Cap	Approx. Dimensions m/m			Objective Life Hours
			s.	d.		Length	Diam.	L.C.L.	
Emergency	100	12	28	6	Special Screw Contact	215	121	135	100
Mains	150	210-30-40-250						160	1000

\* Purchase Tax must be added to the price of this lamp. For the exact amount of purchase tax to be added, see TABLE

A on the extension of page 55.

‡ Cap Illustrations will be found on pages 42 and 43.

NOTE: If ordering by Lamp Reference Number please be sure to state voltage required.

## FILM STUDIO LAMPS

The Tubular Floodlights (see previous page), Studio Spotlights, and “ Broadside ” Lamps fully meet the exacting requirements of film production whether sound or silent, in black and white, or in colour. They are silent in operation. Their light is definite and constant in colour, bringing out the full possibilities of the various film emulsions. They have concentrated light sources of high intrinsic brilliancy, giving the powerful light concentration so necessary for efficient spotlight work, and their absolute reliability has resulted in their adoption almost exclusively by the British film industry. The Colour Temperature Lamps have been specially developed for the making of colour films.

## HOSPITAL THEATRE LAMP

The Hospital Theatre Lamp has a secondary filament which operates off a low volt emergency supply in the event of a mains failure.

# Projector Lamps

STUDIO SPOTLIGHTS  
“ BROADSIDE ”  
COLOUR TEMPERATURE  
HOSPITAL THEATRE



**Mazda**  
lamps  
stay brighter longer



1000w  
STUDIO  
SPOTLIGHT

1500w  
“ BROADSIDE ”

# Neon Switchboard Traction Rough Service



**Mazda**  
lamps  
stay brighter longer



40w ROUGH SERVICE

## NEON LAMPS

Watts	List Price (Purchase Tax Not Chargeable)		Cap §	Approximate Dimensions			
				Maximum Length		Diameter	
				m/m	in.	m/m	in.
<b>Type "N" Nightlight (Voltages 200/220, 230/240, 250/260)</b>							
5	4	6	B.C. (B22/31 x 30) E.S. (E27)	125	4-89	61 (max.)	2-40
<b>Type "Cruciform" (Voltages 200/220, 230/240, 250/260. Containing Cruciform, Letters or Numbers)</b>							
5	7	6	B.C. (B22/31 x 30) E.S. (E27)	125	4-89	61 (max.)	2-40
<b>Type "I" Indicator (Voltages 100, 110, 120, 130, 200/260)</b>							
0-2  0-5†	4	9	S.E.S. (E14/16-5)	30	1-18	12	0-47
			B.C. (B22/22) ....	56	2-21		
			E.S. (E27) ....	58	2-28	28	1-09
			S.B.C. (B15/24 x 17)	54	2-12		
S.E.S. (E14/27 x 18)	56	2-21	18	0-71			
<b>Current Polarity Indicator (Voltages 110/750)</b>							
0-5	8	9	Special	79	3-12	20	0-78
<b>Double Ended Tubular containing letters (Voltages 200/260)</b>							
5-15	12	6	B.C.	390	15-35	42	1-65

† This lamp can be supplied with internal fluorescent coating in Green or Amber. List Price 6s. 0d.

## SWITCHBOARD INDICATOR

Volts †	List Price ‡		Cap §	Approximate Dimensions					
	Clear s. d.	Colour Sprayed s. d.		Overall Length		Diameter			
				m/m	in.	m/m	in.		
100/130 200/260	2	6	2	8	B.C. (B22/21)	56	2-21	28	1-09

‡ Purchase Tax see note below.

† One lamp only is available in each of these voltage ranges, and will be marked 100/130 or 200/260 volts respectively. Lamps are marked "Switchboard Indicator" and no wattage specified.

## TRACTION (Gasfilled, Series Burning)

Nominal Watts	Rated Amps.	Voltages and List Prices ‡				Cap	Approximate Dimensions			
		100, 110, 120, 130					Overall Length		Diameter	
		Clear		Pearl			m/m	in.	m/m	in.
40	0-35	s. d. 1 9†	s. d. 1 9†	B.C. (B22/25 x 26)	110	4-33	60	2-36		
60	0-52	1 9†	1 9†						E.S. (E27/25)	117-5

‡ Purchase Tax see note below.

† With fusible cut-out E.S. cap 40 volt and 50 volt only 2s. 5d. each.

## ROUGH SERVICE (Vacuum, Spiral Filament) CLEAR or PEARL

Watts	Voltages and List Prices ‡		Cap §	Approximate Dimensions				L.C.L.
				Overall Length		Diameter		
				m/m	in.	m/m	in.	m/m
40	s. d. 2 0	200, 210, 220, 230, 240, 250, 260	B.C. (B22/25 x 26)	110	4-33	60	2-36	80
60			or E.S. (E27/25)	117-5	4-61	65	2-56	85

‡ Purchase Tax must be added to the prices in these columns. For the exact amount of purchase tax to be added, see TABLE A on the extension of page 55.

§ Cap illustrations will be found on pages 42 and 43.



NEON INDICATOR

### FAIRY LIGHTS

These attractive lamps provide brilliant colour, making them ideally suitable for festooning public rooms in hotels, restaurants or similar places. Used alone, or in conjunction with Cinderella, Snow-Gem or Fairy Candle sets, they give a warm, colourful display—so essential to Christmas tree decoration.

Price per set . . . . . 18s. 2d.  
Purchase Tax 3s. 5d. extra.

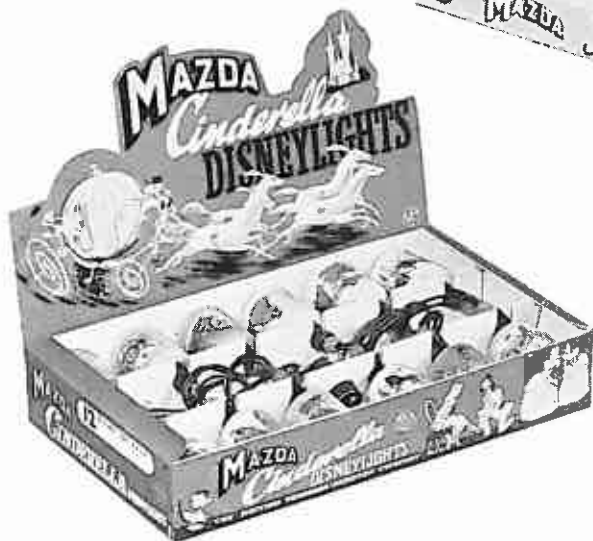

### CINDERELLA (Disneylight)

The colourful characters and scenes from Walt Disney's famous film are faithfully reproduced by means of coloured transfers on the dainty lamp shades. For all festive and decorative lighting Mazda Cinderella sets provide an enchanting atmosphere of gaiety, and children in particular find them a never ending source of pleasure.

Price per set . . . . . 25s. 0d.  
Purchase Tax 4s. 8d. extra.



FAIRY LIGHT

CINDERELLA

### SNOW-GEM FAIRY LIGHTS

"Snow-Gems" are the very latest in decoration lighting sets; each light glistens and sparkles like a flake of snow in the sun. Whether used in the home, in public rooms or for shop-window displays, their resplendent charm is irresistible.

Price per set . . . . . 35s. 0d.  
Purchase Tax 6s. 6d. extra.



SNOW-GEM



### FAIRY CANDLES

Mazda Fairy Candles make an attractive complement to the popular Fairy Lights, Snow - Gems and Cinderella Disneylights produced by BTH. Fairy Candles have the appearance of glowing candles in a variety of gay colours. They are easily clipped to the Christmas tree or to any type of horizontal rod.

Price per set . . . . . 37s. 4d.  
Purchase Tax 6s. 11d. extra.

FAIRY CANDLE



*Each set comprises twelve lights ready wired on a flexible cord for immediate use on 200/260 volt supplies, and one spare lamp. A sliding berry-bead device on each lampholder provides a simple and convenient method of fixing to twigs, projections etc. Spare Mazda 20 volt Decoration Lamps (Clear or Coloured with M.E.S. cap) fit any 12-light set; price 1/- each plus P.T. 2½d.*

# Colour Sprayed

COLOURS AND SIGN  
COLOUR SPRAYED



SIGN  
(EXTERNALLY  
SPRAYED)



SIGN  
(INTERNALLY  
SPRAYED)



G.S.  
(EXTERNALLY  
SPRAYED)

## COLOUR SPRAYED (Single Coil)

Watts	Voltages and List Prices †				Colours Available
	200, 210, 220, 230, 240, 250, 260		100, 110, 120, 130		
	s.	d.	s.	d.	
15	1	8½a	1	8½a	Black and Standard Range →
25	1	8½a	1	8½	
40	1	7½	1	9½	Standard Range →
60	1	7½	1	9½	
75	2	2	2	4	
100	2	2	2	4	
150	3	4	3	6	White Only (wholly or part- ially sprayed)
200	5	3	5	9	
300†	9	3	9	9	
500†	12	3	12	9	

Range of  
Standard Colours

White  
Red  
Blue  
Green  
Yellow  
Flame  
Orange  
Pink  
Amber

\* Purchase Tax must be added to the prices in these columns for lamps up to 250 watts. For the exact amount of purchase tax to be added, see TABLE A on the extension of page 55.

† Lamps over 250 watts are exempt from purchase tax.

‡ Caps and Dimensions as for clear lamps, see page 8.

§ These lamps are vacuum only, all other lamps in the above table are gasfilled. 15w and 25w Lamps may be supplied internally sprayed Red, Green, Yellow, Blue, Orange or White, List Price 1s. 9½d. For 200-260 volts only.

## COLOURED LAMPS

Colour Sprayed General Service and Sign Lamps are ideal for festive illuminations at the seaside, in parks, etc., and for the exterior and interior decoration of such public buildings as halls, cinemas and theatres. Both types of lamp are also extensively used for display lighting and for advertisement signs.

## SIGN LAMPS (Clear and Colour Sprayed in Standard Colours)

Watts	Voltages and List Prices †				Cap ‡	Approx. Dimensions ††	
	100, 110, 130, 200, 210, 220, 230, 240, 250, 260		25, 50, 60, 65, 75			Overall Length m/m	Diameter m/m
	CLEAR s. d.	WHOLLY SPRAYED † s. d.	CLEAR s. d.	WHOLLY SPRAYED † s. d.			
15	1 10	2 0	2 5	2 7	B.C. (B22/22) E.S. (E27) S.B.C. (B15/24 × 17) S.E.S. (E14/27 × 18)	56	28
						58	
						62	
						64	

## SIGN LAMPS (Internally Coloured—Red, Green, Yellow, Blue, White or Orange)

Watts	Voltages and List Prices †				Cap ‡	Approx. Dimensions ††		
	100, 110, 130, 200, 210, 220, 230, 240, 250, 260		200, 210, 220, 230, 240, 250, 260			Overall Length m/m	Diameter m/m	
	s.	d.	s.	d.				
15	2	1	—	—	B.C. (B22/22) E.S. (E27) S.B.C. (B15/24 × 17) S.E.S. (E14/27 × 18)	56	28	
						58		
						62		
						64		
15	—	1	10	2	1	B.C. (B22/22) E.S. (E27)	90	44
							92	

\* Purchase Tax must be added to the prices in these columns. For the exact amount of purchase tax to be added, see TABLE A on the extension of page 55.

† Standard Range of Colours as for Colour Sprayed Lamps.

‡ Cap Illustrations will be found on pages 42 and 43.

†† Lamp outlines are shown on pages 40 and 41.

NOTE.—As an additional safety device, many Mazda lamps incorporate cartridge fuses.

## INFRA RED

Watts	Voltages	List Price *	Cap	Approximate Dimensions					
				Length		Diameter			
<b>WITH INTERNAL REFLECTOR</b>				Parabolic Type Bulb					
150 250	100/130 200/250	s. 12 d. 15	d. 6† 6	E.S. (E27/57×38) Cementless		m/m 155.5 ± 4.5 176 ± 6.5	In. 6.12 6.93	m/m 111 ± 1.5 126 ± 1.5	In. 4.37 4.96
<b>FOR USE WITH EXTERNAL REFLECTOR</b>				Round Bulb					
250	100/130	Clear s. 7 d. 9	Pearl s. 8 d. 3	E.S. (E27/30)	178 ± 5	7.00	90 ± 1	3.54	
<b>RADIANT HEAT</b>				Round Bulb					
60	{ 110-120 210-230-250 }	s. 2 d. 3	{ B.C. (B22/25×26) or E.S. (E27/25) }	117.5 ± 3.5	4.61	65 ± 1	2.56		

\*Purchase Tax must be added to the prices of these lamps unless exemption has been obtained.  
For the exact amount of purchase tax to be added, see TABLE A on the extension of page 55.  
† Available with crown red glazed externally. List Price 14s. 0d.

## INFRA-RED LAMPS

Mazda 250-watt Infra-Red Lamps are extensively used for Industrial baking, drying and agricultural processes, and because of their wavelength they are also suitable for heat therapy both in the home and the clinic. Visible light forms only a small percentage of radiant energy, the bulk of which is produced at the invisible infra-red wavelengths.

### REFLECTOR TYPE

The reflector type lamp has a parabolic shaped bulb which is light diffused frosted. The upper half of the bulb is coated on the inside with aluminium to form an efficient reflector which concentrates the radiant energy from the filament into a beam which has a total spread of not more than 120 degrees. Being protected by the glass and the inert gas filling, the reflector does not tarnish and therefore its initial efficiency is maintained to a high degree throughout the lamp life. The outer surface of the glass bulb can readily be cleaned to prevent reduction of the radiation by dust, paint splashes etc., and the lamp is fitted with a mechanically attached (cementless) cap to enable it to withstand the severe heating conditions in an infra-red oven. Since no external reflector is required, lamps can be mounted close together and this permits a high degree of concentration where it is desirable. The 100/130 volt lamps may be used two in series on 200/250 volt supplies.

### NON-REFLECTOR TYPE

The non-reflector lamp, for maximum efficiency, must be used in conjunction with an external reflector. This lamp has two finishes—satin frosted or clear. The former is generally to be preferred since the frosting helps to smooth out hot spots. These lamps operate two in series on 200/250 volt supplies.

### RADIANT HEAT

The 60 watt Radiant Heat Lamp has a metal filament and is specially designed for use in clinical apparatus employed for heat therapy in hospitals and clinics.



250w  
INTERNAL  
REFLECTOR

# Infra-red Lamps

REFLECTOR AND  
NON-REFLECTOR  
TYPES FOR  
INDUSTRIAL  
DRYING AND BAKING



**Mazda**  
lamps  
stay brighter longer

# Just a few reasons why

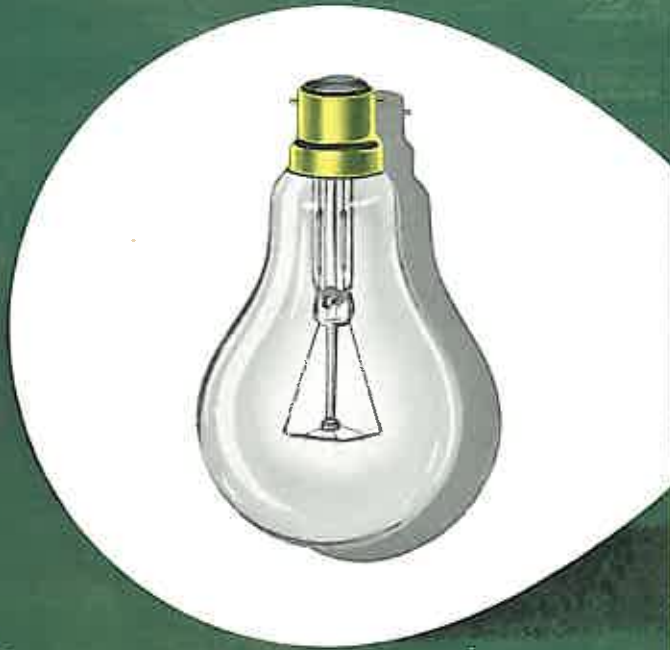

## G.L.S. LAMPS

**Moulded Necks.** The fully insulated cap on a Mazda Lamp will withstand a twisting strain of over 25 lb.-in. This is because the glass neck has moulded ridges which form a key for the special heat and damp resisting resin cement.

**Fuses.** All Mazda Coiled-coil Lamps are fitted with internal cartridge fuses and they are also incorporated in single-coil lamps wherever it is necessary for safety, or desirable to permit greater efficiency.

**"Vitalized" Filaments.** Mazda tungsten filaments are processed with silica and alumina at 6,000°F; more than twice the temperature of molten steel. This "vitalizing" process ensures that they never sag.

**Triple Purified Argon.** The argon gas in Mazda Gasfilled Lamps is purified not just once but three times. In the finished product there is less than one part in a million of impurity.

**Any Way up.** It does not matter which way up you fit a Mazda G.L.S. Lamp. Improved methods of manufacture prevent the considerable shortening of life that was once associated with 'cap-down' burning.

## FLUORESCENT LAMPS

**Halophosphate Coatings.** The light from a fluorescent lamp comes from the powder on the inside of the tube which is made to fluoresce by ultra-violet radiation. Halophosphates form the most efficient coating yet discovered. Their use means greater light output and longer effective life for Mazda Fluorescent Lamps.

**Thoriated Tungsten Electrodes.** The electrodes in Mazda Fluorescent Lamps are made from thoriated tungsten because tests have proved that its minute crystals interlock to form the most durable and efficient material for this purpose.

**Alkaline Electrode Coatings.** To facilitate starting and maintaining the discharge, the electrodes are coated with the oxides of Barium and Strontium.

**Cadmium Borate.** Where a more natural colour rendering is required, as in Mazda Mellow Lamps, Cadmium Borate is added to the powder to strengthen the red end of the spectrum.

**Precision Built.** Every stage in production is closely regulated. For instance, if the coating of powder in the tube is either a fraction too thin or a fraction too thick, light output will be reduced. The weight of coating powder in Mazda Fluorescent Lamps is exact to 1/140 oz. per foot of tube.



THE LAMPS WITH



BEHIND THEM

# Mazda lamps stay brighter longer



## PROJECTOR LAMPS

**Mazda Projector Lamps** provide a concentrated and constant source of brilliant light. They are robustly made to give the longest and most reliable service possible, and are precision-built to the finest tolerances for accurate focusing.

**Jig-formed Filament Supports.** Precise alignment of the filament segments is ensured by the use of mechanically formed filament supports. This eliminates the strains and distortion previously associated with hand forming, and results in greatly improved screen lumen maintenance.

**Threaded Contact Plug.** Electrical contact between filament and lead is positively ensured by a special threaded plug, thus achieving greater durability both at the filament juncture and at the lead-in wire weld.

**Multi-section Leads.** Expansion characteristics of the filament and its mount are carefully matched to prevent distortion.

**Mechanically Formed Filaments.** A more concentrated light source and more uniform performance over life than ever before results from the use of mechanically formed filaments.

**Temperature Resistant Alloys.** Special alloys with a low coefficient of expansion are used wherever necessary to increase the strength of welds and to keep the filament in exact focus.

## ELECTRIC DISCHARGE LAMPS

### SODIUM VAPOUR

**"Hard" Glasses.** Tubes are now made from new glasses highly resistant to thermal shock.

**"Fernico" Seals.** "Fernico" alloy seals are invulnerable to sodium corrosion; concomitant annealing and glassworking techniques ensure a complete metal-to-glass union.

**Pure Metallic Sodium.** Double distillation of the metallic sodium, combined with special treatment of the glass surface, results in maximum light output through life.

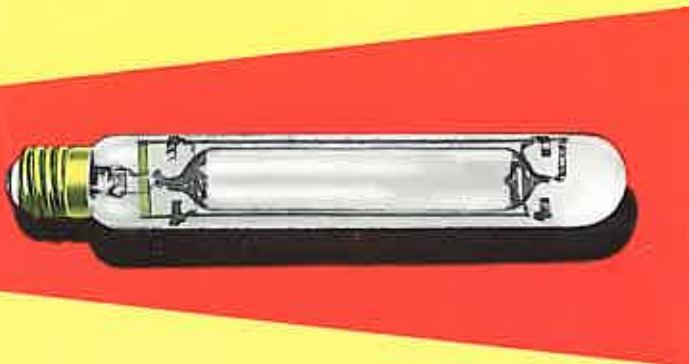
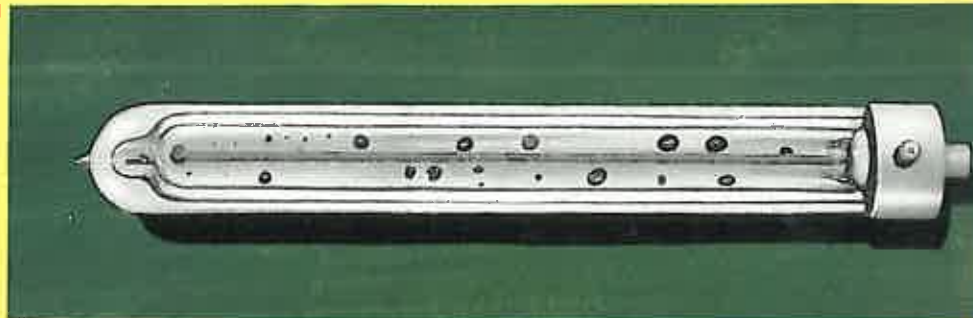

### MERCURY VAPOUR (TYPE MA)

**Emissive Pellets.** Thoriated emissive pellets give reliable striking throughout life.

**Double Helix Electrodes.** Each electrode is designed to protect its emissive pellet and thus helps to improve lumen maintenance.

**Accurate Filling.** The mercury filling is micrometer controlled to ensure maximum life and light output in each voltage range.

**Improved Arc Tube Mount.** Introduction of a new arc tube mount obviating point suspension gives greatly increased resistance to external vibrations.

# Motor Car Bulbs

(Motor Cars, Motor Cycles & Commercial Vehicles)

SINGLE AND DOUBLE FILAMENT



**Mazda lamps stay brighter longer**

## SINGLE FILAMENT HEADLAMPS

Lamp No.	Volts	Watts	Filament	Cap	Dimensions		List Price s. d.
					Length m/m	Diam. m/m	
605	6	24	Axial	3-pin B.C.(BA.21s 3-pin)	61	38	2 9
106	6	24	Axial	S.C.C.(BA.15s/17)	56		2 6
109	6	24	Axial	S.B.C.(BA.15d/17)	56		2 7
108	6	36	Axial	S.C.C.(BA.15s/17)	56		2 9
374†	6	36	Axial	S.C.C.(BA.15s/17)	56		4 0
607	6	36	Axial	S.C.C.(BA.15s/17)	61		3 0
130	6	36	Axial	3-pin B.C.(BA.21s 3-pin) Bosch Single Contact (BA.20s)	67		3 0
75	6	36	Transverse	S.C.C.(BA.15s/17)	56		2 9
111	6	36	Axial	S.B.C.(BA.15d/17)	56		2 10
608	6	36	Transverse	S.C.C.(BA.15s/17)	56		3 0
1	12	24	Axial	S.C.C.(BA.15s/17)	56		2 6
2	12	36	Axial	S.C.C.(BA.15s/17)	56		2 6
612	12	36	Axial	S.C.C.(BA.15s/17)	61		2 9
57	12	36	Transverse	3-pin B.C.(BA.15s/17)	56		2 6
375†	12	36	Axial	S.C.C.(BA.15s/17)	56		3 9
5	12	36	Axial	S.B.C.(BA.15d/17)	56	2 7	
615	12	36	Transverse†	S.C.C.(BA.15s/17)	56	3 0	
616	12	48	Axial	3-pin B.C.(BA.21s 3-pin)	61	4 3	
23	12	48	Axial	S.C.C.(BA.15s/17)	56	4 0	
27	12	48	Axial	S.B.C.(BA.15d/17)	56	4 1	
96	12	48	Axial	Bosch Single Contact (BA.20s)	67	4 3	
618	12	60	Axial	3-pin B.C.(BA.21s 3-pin)	69	5 9	
90	12	60	Axial	S.C.C.(BA.15s/17)	63	5 6	
26	12	60	Axial	S.B.C.(BA.15d/17)	63	5 7	
87	12	60	Axial	Bosch Single Contact (BA.20s)	74	5 9	
621	24	36	Axial(a)	S.C.C.(BA.15s/17)	56	2 8	
123	24	36	Axial(a)	S.B.C.(BA.15d/17)	56	2 8	
622	24	36	Axial(a)	B.C.(B22/22)	56	2 8	
623	24	48	Axial(a)	S.C.C.(BA.15s/17)	56	4 3	
140	24	48	Axial(a)	S.B.C.(BA.15d/17)	56	4 3	
624	24	48	Axial(a)	B.C.(B22/22)	56	4 3	
124	24	60	Axial(a)	S.C.C.(BA.15s/17)	63	5 9	
128	24	60	Axial(a)	S.B.C.(BA.15d/17)	63	5 9	
127	24	60	Axial(a)	B.C.(B22/22)	63	5 9	
131	24	60	Axial(a)	Bosch Double Contact (BA.20d)	74	6 0	

\* Purchase Tax see note below.

† Cadmium Yellow Bulb for use on the Continent. † Single Coil or Coiled Coil. (a) Coiled Coil.

## DOUBLE FILAMENT HEADLAMPS

(Filament :—Vertical Dip. Main Filament on the Axis)

Lamp No.	Volts	Watts	Filament	Cap	Dimensions		List Price s. d.
					Length m/m	Diam. m/m	
180	6	18 & 18	Transverse	S.B.C.(BA.15d/17)	56	38	4 6
168	6	24 & 24	"	S.B.C.(BA.15d/17)	56		3 6
183	6	24 & 24	"	Bosch Double Contact (BA.20d)	67		3 9
169	6	30 & 30	"	S.B.C.(BA.15d/17)	56		3 6
628	6	30 & 30	"	3-pin B.C.(BA.21d 3-pin)	61		3 9
171	12	36 & 36	"	S.B.C.(BA.15d/17)	56		3 6
630	12	36 & 36	"	3-pin B.C.(BA.21d 3-pin)	61		3 9
376†	12	36 & 36	"	S.B.C.(BA.15d/17)	56		4 9
633	12	36 & 36	"	A.S.B.C.(BA.15d/21)	59		3 6
182	12	36 & 36	"	Bosch Double Contact (BA.20d)	67		3 9
194	24	36 & 36	Transverse(a)	S.B.C.(BA.15d/17)	56		5 0

\* Purchase Tax must be added to the prices in these columns. For the exact amount of purchase tax to be added see TABLE B on the extension of page 55.

† Cadmium Yellow Bulb for use on the Continent. (a) Coiled Coil.

## MAZDA HEADLAMPS

Gasfilled tungsten filament lamps have proved to be by far the most satisfactory means of providing a headlight of sufficient versatility to meet the exacting and changing requirements of the road. In normal conditions, they have an efficiency of from 15-19 lumens per watt, according to rating, voltage and objective life.



12v 36 and 36w DOUBLE FILAMENT No. 171



12v 36w SINGLE FILAMENT No. 2



## SINGLE FILAMENT PREFOCUS HEADLAMPS

(Caps:—Single Contact P22s/21, Double Contact P22d/21)

Lamp No.	Volts	Watts	Filament	Contact	Dimensions		List Price s. d.
					Length m/m	Diam. m/m	
172	6	36	Axial Single Coil	Single	62 max.	28 ± 1	3 9
173	6	36	Trans. Single Coil	Single			3 9
162	12	36	Axial Single or Coiled Coil	Single			3 9
177	12	36	Axial Single or Coiled Coil	Double			3 9
325†	12	38	Trans. Single Coil	Single			3 9
326†	12	38	Trans. Single Coil	Double			3 9
323	12	48	Trans. Single or Coiled Coil	Single			4 9
600‡	12	48	Trans. Single or Coiled Coil	Single			6 0
185	12	48	Axial Single or Coiled Coil	Single			4 9
331†	24	44	Axial Coiled Coil	Double			5 0
330†	24	44	Trans. Coiled Coil	Double			5 0
601‡	24	44	Trans. Coiled Coil	Double			6 3

\* Purchase Tax see note below.

† For Commercial Vehicles only. ‡ Cadmium Yellow Bulb for use on the Continent.

## DOUBLE FILAMENT PREFOCUS HEADLAMPS

(Caps:—Double Contact P22d/21)

(Dimensions—Length 62 m/m max. Diam. 28 ± 1 m/m)

Lamp No.	Volts	Watts	Filament (Main on the axle)	Contact	Dipping Arrangements		List Price s. d.
					Dip	Drive	
311	6	18 & 18	Single Coil	Double	Vertical	Either	5 3
166	6	24 & 24	Single Coil	Double	Vertical	Either	4 9
312	6	30 & 24	Single Coil	Double	Vertical	Either	5 6
373	6	30 & 24	Single Coil	Double	Left	R/Hand	5 6
602‡	6	30 & 24	Single Coil	Double	Vertical	Either	6 9
356	6.4	45 & 35	Single Coil	Double	Left	R/Hand	5 9
354	12	42 & 36	Single Coil	Double	Left	R/Hand	5 0
355	12	42 & 36	Single Coil	Double	Right	L/Hand	5 0
603‡	12	42 & 36	Single Coil	Double	Left	R/Hand	6 3
604‡	12	42 & 36	Single Coil	Double	Right	L/Hand	6 3
358†	12	44 & 38	Single Coil	Double	Left	R/Hand	6 3
302¶	12	48 & 48	Single or Coiled Coil	Double	Left	R/Hand	6 9
404§	12	60 & 36	Single Coil	Double	Left	R/Hand	7 6
359†	24	44 & 38	Coiled Coil	Double	Left	R/Hand	7 0

\* Purchase Tax see note below.

† For Commercial Vehicles only. ‡ Cadmium Yellow Bulb for use on the Continent. ¶ Both filaments are offset.

§ 38 m/m dia. bulb.

## AMERICAN TYPE PREFOCUS

Lamp No.	Volts	Watts	Filament	Cap	Dimensions		List Price s. d.
					Length m/m	Diameter m/m	
619	12	60	Transverse	P15s/19	65	50	6 0
629	6	30 & 30	"	P15d/19	58	38	4 0
632	12	36 & 36	"	P15d/19	58	38	4 0

\* Purchase Tax must be added to the prices in these columns. For the exact amount of purchase tax to be added see TABLE B on the extension of page 55.

## PREFOCUS HEADLAMPS

Though many motor cars still operate with headlamps fitted with bayonet caps, the modern trend is toward the use of pre-focus caps, which maintain the original beam character whenever and wherever replacement bulbs are needed.

# Motor Car Bulbs

(Motor Cars, Motor Cycles & Commercial Vehicles)

PREFOCUS SINGLE AND DOUBLE FILAMENT



**Mazda** lamps stay brighter longer



12v 36w AXIAL FILAMENT No. 162



12v 42 and 36w TRANSVERSE FILAMENT No. 354

# Motor Car Bulbs

(Motor Cars, Motor Cycles & Commercial Vehicles)

**SIDE AND TAIL  
STOP  
INDICATOR  
FESTOON  
BUS**



**Mazda  
lamps  
stay brighter longer**



INDICATOR



SIDE/TAIL



FESTOON



STOP/TAIL

## SIDE AND TAIL LAMPS (Bow Filament)

Lamp No.	Volts	Watts	Cap	Dimensions		List Price	
				Length m.m.	Diameter m.m.	s.	d.
200	6	3	S.C.C. (BA.15s/17)	32.5	18	1	4
204	6	3	S.B.C. (BA.15d/17)	32.5	18	1	5
988	6	3	M.C.C. (BA.9s/14)	28	15	1	6
205	6	6	S.C.C. (BA.15s/17)	32.5	18	1	7
206	6	6	S.B.C. (BA.15d/17)	32.5	18	1	8
207	12	6	S.C.C. (BA.15s/17)	32.5	18	1	4
209	12	6	S.B.C. (BA.15d/17)	32.5	18	1	5
222	12	4	M.C.C. (BA.9s/14)	28	15	1	7
989	12	6	M.C.C. (BA.9s/14)	28	15	1	7
149	24	6	S.C.C. (BA.15s/17)	32.5	18	1	6(c)
150	24	6	S.B.C. (BA.15d/17)	32.5	18	1	6(c)
638	24	6	B.C. (B22/22 x 16)	37	18	1	6(c)

\* Purchase Tax see note below. (c) 'V' Filament no extra.

## STOP and STOP/TAIL LAMPS (Bulb Diam.—25 m/m. Filament:—Transverse)

Lamp No.	Volts	Watts	Cap	Length m.m.	List Price
					s. d.
190	6(d)	3 & 18	S.B.C. (BA.15d/17)	45.5	3 6(e)
352	6(d)	3 & 18	S.B.C. Index (BA.15d/19)†	47	3 9
369	12(d)	6 & 18	S.B.C. (BA.15d/17)	45.5	3 6(e)
361	12(d)	6 & 18	S.B.C. Index (BA.15d/19)†	47	3 9
317	6(s)	18	A.S.C.C. (BA.15s/21)	49	3 9
221	12(s)	18	A.S.C.C. (BA.15s/21)	49	3 6

\* Purchase Tax see note below. (d) Double Filament. (e) 'V' Shape Auxiliary Filament No extra. (s) Single Filament. † Index pln.

## INDICATOR LAMPS

Lamp No.	Volts	Watts	Cap	Dimensions		List Price	
				Length m.m.	Diameter m.m.	s.	d.
990	6	3	M.E.S. (E10/13)	23	11	1	3
641	6	3	M.C.C. (BA.9s/14)	23.5	11	1	6
981	6	3	M.E.S. (E10/13)	27.5	15	1	3
642	6	3	M.C.C. (BA.9s/14)	28	15	1	6
987	12	2.2	M.E.S. (E10/13)	23	11	1	3
643	12	2.2	M.C.C. (BA.9s/14)	23.5	11	1	6
986	12	2.2	M.E.S. (E10/13)	27.5	15	1	3
645	12	2.2	M.C.C. (BA.9s/14)	28	15	1	6
985†	16	3	M.E.S. (E10/13)	27.5	15	2	3
647†	16	3	M.C.C. (BA.9s/14)	28	15	2	6
993†	24	2.8	M.E.S. (E10/13)	27.5	15	1	8
651†	24	2.8	M.C.C. (BA.9s/14)	28	15	1	11

\* Purchase Tax see note below. † With Supported Filament.

## FESTOON LAMPS (Cap:—S 7/8 or S 8-5 B)

Lamp No.	Volts	Watts	Dimensions		List Price	
			Length m.m.	Diameter m.m.	s.	d.
255	6	3	35.5	7.5	2	3
253	6	6	38	11	2	7
256	12	3	35.5	7.5	2	3
254	12	6	38	11	2	7
653	24	6	38	11	2	6
654†	24	6	38	11	4	6
260	24	6	44	11	3	0

† With Supported Filament.

## BUS INTERIOR LAMPS (Pearl) Standard Caps:—B.C. (B22/21 x 26) or S.B.C. (BA.15d/17) Filaments:—"V" or Bow

Volts	Watts	Dimensions				List Price	
		Length		Diameter		s.	d.
		m.m.	in.	m.m.	in.		
12	12	55 (B.C.)	2.17	38	1.50	2	4
24	12	56 (S.B.C.)	2.20	38	1.50	2	6
24	20	68	2.68	50	1.97	2	9

\* Purchase Tax must be added to the prices in these columns. For the exact amount of purchase tax to be added see TABLE B on the extension of page 55.

## FLASHLIGHT LAMPS

Lamp No.	Volts	Amps.	Cap	Diam. m.m	List Price s. d.	P.T.
970	2.5	0.2	M.E.S.	11	0 4	1d.
972	2.5	0.3	M.E.S.	11	0 4	1d.
974	3.5	0.15	M.E.S.	11	0 4	1d.
977	3.5	0.3	M.E.S.	11	0 4	1d.
—	4	0.3	M.E.S.	11	0 4	1d.
—	4.5	0.3	M.E.S.	15	0 4	1d.
—	1.5	0.11	M.E.S.	15	0 8	1½d.
—	2	0.6	M.E.S.	15	0 8	1½d.
—	5	0.15	M.E.S.	15	0 8	1½d.

Extra: For varnishing 2d. each extra list or 8/- nett per 100.

## LENS END FLASHLIGHT LAMP

Volts	Amps.	Cap	Diam. m/m	List Price s. d.	P.T.
2.2	0.25	M.E.S.	9.5 max.	0 7	1½d.

## PREFOCUS FLASHLIGHT LAMPS

Volts	Amps.	Diam. m.m	List Price s. d.	P.T.
2.5	0.2	11	1 0	2d.
2.5	0.3	11	1 0	2d.
3.5	0.3	11	1 0	2d.

## RADIO PANEL LAMPS

Volts	Amps.	Cap	Diam. m/m	List Price s. d.	P.T.	Volts	Amps.	Cap	Diam. m.m	List Price s. d.	P.T.
<b>ROUND BULB</b>											
6	0.04	M.E.S.	11	1 0	2d.	6.2†	0.3	M.E.S.	15	0 7	1d.
6	0.06	M.E.S.	11	1 0	2d.	6.3	0.11	M.E.S.	11	0 7	1d.
						6.5	0.3	M.E.S.	11 or 15	0 7	1d.
<b>TUBULAR BULB</b>											
6.2†	0.3	M.E.S.	10	0 7	1d.	6.5	0.3	M.E.S.	10	0 7	1d.
6.3†	0.15	M.E.S.	10	0 7	1d.						

Extras: For varnishing 2d. each. extra list or 8/- nett per 100. † Objective life 10 hours.

## VACUUM POLICE LAMPS

Volts	Amps.	List Price s. d.	Cap	Approximate Dimensions			
				Length		Diameter	
				m/m	In.	m/m	In.
2	0.75	2 6	Wootton B9-5s/11	28	1.09	18	0.71
2	0.75	2 6	M.E.S. (E10/13)	27.5	1.08	15	0.59

\* Purchase Tax must be added to the prices in this column. For the exact amount of purchase tax to be added see TABLE B on the extension of page 55.

## CYCLE DYNAMO LAMPS HEAD

Volts	Amps.	Cap	Diam. m.m	List Price s. d.	P.T.
6a	0.2	M.E.S.	15	0 8	1½d.
6a	0.3	M.E.S.	15	0 8	1½d.
6a	0.45	M.E.S.	15	0 8	1½d.
6a	0.5	M.E.S.	15	0 8	1½d.
6	0.3	S.C.C.	18	1 4	3d.
6	0.5	S.C.C.	18	1 4	3d.

a Also available with striated bulbs, which give better light diffusion.

## CYCLE DYNAMO LAMPS TAIL

Volts	Amps.	Cap	Diam. m.m	List Price s. d.	P.T.
1.5	0.15	M.E.S.	15	0 8	1½d.
3.5	0.15	M.C.C.	11 or 15	0 8	1½d.
6	0.04	M.E.S.	11 or 15	0 8	1½d.
6	0.10	M.E.S.	11	0 8	1½d.

## CYCLE SPEEDOMETER LAMP

Volts	Amps.	Cap	Diam. m.m	List Price s. d.	P.T.
6.5	0.3	M.C.C.	11	0 8½	1½d.

# Cycle Flashlight Radio Panel & Police Lamps



**Mazda** lamps stay brighter longer



LENS END FLASHLIGHT LAMP



PREFOCUS FLASHLIGHT LAMP



FLASHLIGHT LAMP



6v 0.04 amp. CYCLE TAIL



6v 0.5 amp. CYCLE HEAD



6v 0.45 amp. CYCLE HEAD (Striated Bulb)

# Miners' Lamps

## MINERS' CAP AND HANDLAMPS



**Mazda**  
lamps  
stay brighter longer

## MINERS' CAP (Clear Bulb) *(Purchase Tax not chargeable)*

Lamp Code Number	Rating		List Price Each s. d.	Diameter		Length		MFP Category	Cap
	Volts	Amps.		m/m	In.	m/m	In.		
<b>ARGON—DOUBLE FILAMENT</b>									
13B	4-0	0-55 & 0-55	2 9	25	0-98	49	1-93	1 (B)	BA.15d/21
<b>KRYPTON—SINGLE FILAMENT</b>									
13A	3-6	1-0	2 10	18	0-71	31	1-22	3/1	E10
15A	4-0	0-8	2 10	18	0-71	31	1-22	2	E10
<b>KRYPTON—DOUBLE FILAMENT</b>									
14A	3-75	1-0 & 1-0	3 6	18	0-71	40	1-60	3/2	BA.15d/17

## MINERS' HANDLAMP (Pearl Bulb)

Lamp Code Number	Rating		List Price Each s. d.	Diameter		Length		MFP Category	Cap
	Volts	Amps.		m/m	In.	m/m	In.		
<b>KRYPTON—SINGLE FILAMENT †</b>									
11B	2-5	1-5	3 0	18	0-71	43-5	1-69	1 (B)	953
12B	2-5	1-5	3 0	18	0-71	45-5	1-80	1 (B)	E14
11A	2-5	1-75	3 0	18	0-71	43-5	1-69	3/1	953
12A	2-5	1-75	3 0	18	0-71	45-5	1-80	1 (B)	E14
14B	4-0	0-75	3 0	18	0-71	45-5	1-80	1 (B)	E14
15B	4-0	0-75	3 0	18	0-71	47a	1-85	1 (B)	Peg
16A	4-0	1-0	3 0	18	0-71	45-5	1-80	1 (B)	E14

† Supplied with fuse in the cap. (a) With Pip.

E 14 = E 14/23 x 15 = S.E.S. E 10 = E 10/13 = M.E.S. 953 = Special S.C.C. BA.15d/17 or BA.15d/21 = S.B.C.

All the Miners' Lamps listed on this page are approved by the Mines Department and are exempt from Purchase Tax.



**HANDLAMP**  
2-5v 1-5 amp.  
E 14 CAP



**MINERS' CAP**  
3-6v 1-0 amp.  
E 10 CAP



**MINERS' CAP**  
4v 0-55 AND  
0-55 amp.  
BA.15d/21 CAP

# AIRCRAFT LAMPS

Watts	Volts	List Price †		Cap	Filament	Type and Finish	Approximate Dimensions						
		s.	d.				Length		Diameter		L.C.L.		
							m/m	In.	m/m	In.	m/m	In.	
<b>LANDING</b>													
240	12	29	0A	P28/25	Twin Pillar	Clear G.F.	95	3-74	60	2-36	37±0-5	1-46	
240	26	29	0A	P28/25	Tr. C.C.	Clear G.F.	95	3-74	60	2-36	44-5	1-75	
350	26	33	0	P40/41	Tr. C.C.	Clear G.F.	120	4-72	75	2-95	43	1-69	
<b>INSTRUMENT or INDICATOR LAMPS</b>													
1-2	12	2	2C	End piece and Clips	—	Clear Vac.	38	1-50	6-5	0-26	—	—	
2-4	24	2	2C				—	Clear Vac.	38	1-50	6-5	0-26	—
6	12	2	7B	S8-5/8	Axial	Clear Vac.	38	1-50	11	0-43	—	—	
6	24	2	6B	S8-5/8	Axial	Clear Vac.	38	1-50	11	0-43	—	—	
2-36	6-5	7½B	E10/13	Tra. Bow or "V"	—	Clear Vac.	23	0-91	11	0-43	—	—	
2-2	12	1	3B				E10/13	Bow or "V"	Clear Vac.	27-5	1-08	or 15	or 0-59
2-8	24	1	8B	E10/13	Bow or "V"	Vac.	27-5	1-08	or 15	or 0-59	—	—	
<b>WARNING LAMPS</b>													
0-24	3	1	0B	E10/13	Tra. Bow or "V"	Clear Vac.	23	0-91	11	0-43	—	—	
0-24	6	1	0B	E10/13	Tra. Bow or "V"	Vac.	23	0-91	11	0-43	—	—	
<b>COCKPIT</b>													
7	12	3	0B	BA.15d/17	Bow or "V"	Clear G.F.	32-5	1-28	18	0-71	17-5	0-69	
2-2	12	1	5B	E10/13	Bow or "V"		Varnished	27-5	1-08	or 15	or 0-47	—	—
2-8	24	1	11B	E10/13	Bow or "V"			Red Vac.	27-5	1-08	or 15	or 0-59	—
<b>GENERAL SERVICE LAMPS</b>													
6	12	1	5B	BA.15d/17	Bow or "V"	Clear G.F.	32-5	1-28	18	0-71	—	—	
6	24	1	8B	BA.15d/17	Bow or "V"		Vac.	32-5	1-28	18	0-71	—	—
<b>CABIN LAMPS</b>													
12	12	2	4B	BA.15d/17	Bow or "V"	Clear G.F.	56	2-20	38	1-50	—	—	
12	24	2	9B	BA.15d/17	Bow or "V"		Clear G.F.	56	2-20	38	1-50	—	—
<b>NAVIGATION, HEAD, TAIL, and SIDE</b>													
10	12	3	6B	BA.15d/17	Single T Coll Special Trans.	Clear G.F.	46	1-81	25	0-98	30	1-18	
10	24	4	6B	BA.15d/17		Clear Vac. or G.F.	46	1-81	25	0-98	30	1-18	
20	12	4	0B	BA.15d/17		Clear G.F.	57	2-24	38	1-50	33	1-30	
20	24	4	6B	BA.15d/17		Clear G.F.	57	2-24	38	1-50	33	1-30	
<b>IDENTIFICATION DOWNWARDS</b>													
30	12	5	0B	BA.15d/17	Special	Internally Frosted G.F.	58	2-28	27	1-06	38	1-50	
80	24	7	6B	BA.15d/17			Special	58	2-28	38	1-50	38	1-50
<b>TAXYING</b>													
36	12	2	7B	BA.15d/17	"V"	Clear G.F.	56	2-20	38	1-50	28-5	1-12	
60	24	6	0B	BA.15d/17	Ax. C.C. or "V"		Clear G.F.	56	2-20	38	1-50	28-5	1-12

\*Purchase Tax must be added to the prices of all lamps in this column except the 350 w. 26 v. Landing lamp. The exact amount of Purchase Tax to be added to the list prices with the suffixes "A" and "B" will be found in TABLES A and B respectively on the extension of page 55. Purchase Tax equal to 18½% must be added to list prices with the suffix "C."

# Aircraft Lamps

**GENERAL SERVICE  
INSTRUMENT  
WARNING  
COCKPIT  
CABIN  
NAVIGATION  
IDENTIFICATION  
TAXYING  
LANDING**



**Mazda lamps**  
stay brighter longer



IDENTIFICATION



CABIN

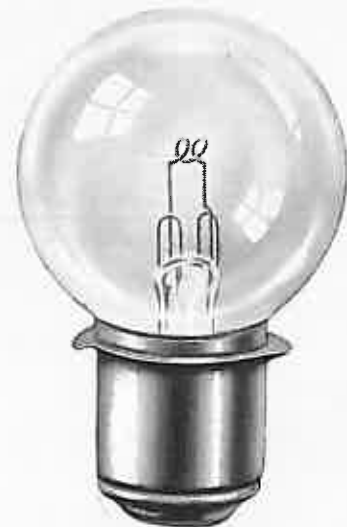

LANDING

# Electric Discharge

MERCURY VAPOUR  
TYPE MB/V, MA/V  
AND MA/U



**Mazda**  
lamps  
stay brighter longer



80w TYPE MB/V

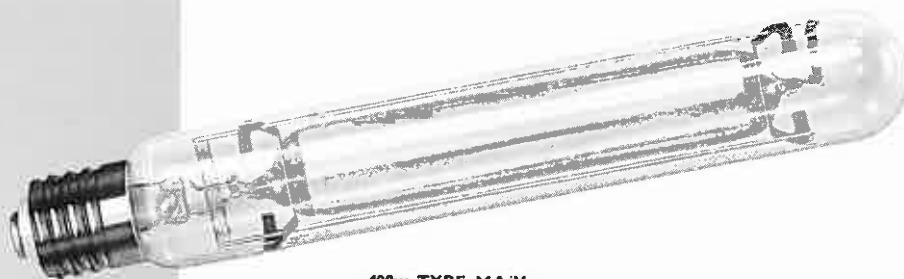

400w TYPE MA/V  
OR MA/U

## MERCURY VAPOUR (Purchase Tax not chargeable)

Watts †	A.C. Voltages	List Price s. d.	Cap ‡	Approximate Dimensions m/m		
				Length	Diameter	L.C.L.
<b>TYPE MB/V</b>				<b>Round Bulb</b>		
80 125 1000	} 200/220, 230/240, 250  350/450	} 39 6 45 0 160 0	} 3-pin B.C. (B22/31 x 30)  G.E.S. (E40/45)	160	80	113
				178	90	128
				335	165 max.	200
<b>TYPE MA/V</b>				<b>Tubular Bulb</b>		
250 400	} 100, 110, 120, 130, 200/220, 230/240, 250	} 54 0a 59 0a	} G.E.S. (E40/45)	290	51	170
				330	51	190
<b>TYPE MA/U</b>				<b>Tubular Bulb</b>		
250 400	} 200/220, 230/240, 250	} 57 6a 62 6a	} G.E.S. (E40/45)	290	51	170
				330	51	190

a These prices are for Soft Glass Envelope; hard Glass Envelopes are available if required, at extra cost.

‡ Cap Illustrations will be found on pages 42 and 43.

† Lamp Outlines are shown on pages 40 and 41.

‡ Light Output of these lamps is given on page 44.

IMPORTANT NOTE.—Mazda Electric Discharge Lamps are made to operate on standard supply voltages with appropriate Lamp Auxiliary Gear. See pages 46 and 47.

## MERCURY VAPOUR LAMPS

(see centre pages)

These lamps find their principal applications in streetlighting, floodlighting, and industrial lighting.

The lamp consists of two envelopes, the space between the inner and outer envelope being for heat retention purposes. The electrodes, which require no separate heating transformers, are mounted one at each end of the inner tube and give a high electronic emission when incandescent. A third electrode situated close to one of the main electrodes and connected to the mains through a series resistance serves to stimulate conduction at starting.

Each lamp requires a choke in series with it, to control the current passing, since the lamp has no electrical resistance of its own; in some cases certain other auxiliary equipment is desirable, such as a capacitor connected across the mains for power-factor correction.

## MERCURY VAPOUR FLUORESCENT (Purchase Tax not chargeable)

Watts†	A.C. Voltages	List Price s. d.	Cap ‡	Approximate Dimensions m/m†			
				Length	Overall Diam.	Neck Diam.	L.C.L.
<b>TYPE MBF/V</b>				<b>Round Bulb</b>			
80	200/220, 230/240, 250	48 6	3-pin B.C. (B22/31 x 30) G.E.S. (E40/45) or 3-pin B.C. (B22 31 x 30)	160	80	39	113
125		59 0		183 178	90 90	39 39	133 128
<b>TYPE MAF/V</b>				<b>Iso-thermal Bulb</b>			
400	200/220, 230/240, 250	81 6	G.E.S. (E40/45)	335	165	50	—

§ Cap Illustrations will be found on pages 42 and 43.

† Lamp Outlines are shown on pages 40 and 41.

‡ Light Output of these lamps is given on page 44.

IMPORTANT NOTE.—Mazda Electric Discharge Lamps are made to operate on standard supply voltages with appropriate Lamp Auxiliary Gear. See pages 46 and 47.

### MERCURY VAPOUR FLUORESCENT LAMPS

The light from the ordinary mercury discharge lamp, because of the small emission of red light, has a distorting effect upon certain colours. It is impossible for instance, to distinguish between reds and various shades of brown. The mercury vapour lamp with fluorescent bulb has been developed to meet requirements where a good degree of colour rendering is important, and further lamp development by BTH has brought about even better colour rendering and smaller bulb sizes.

The mercury vapour discharge tube is mounted in an outer jacket, the inner surface of which is coated with powder which fluoresces under ultra-violet radiation from the inner lamp. This fluorescent radiation provides colour correction, by adding red light which blends with the characteristic blue of the mercury vapour emission to give a resultant white light.

The electrical characteristics of these lamps are similar to the standard Mazda mercury vapour lamps in that they require to be operated with a standard choke and, where necessary, a capacitor for power factor correction.

# Electric Discharge

MERCURY VAPOUR  
TYPES MBF/V, MAF/V



**Mazda**  
lamps  
stay brighter longer



400w TYPE MAF/V



125w TYPE  
MBF/V

# Electric Discharge

**SODIUM VAPOUR  
TYPE SO/H**



**Mazda**  
lamps  
stay brighter longer

## SODIUM VAPOUR (Purchase Tax not chargeable)

Wattage	A.C. Voltages (See text below)	List Price				Cap B.C. Ceramic	Approx. Dimensions m/m†		
		Without Jacket		With Clear Detachable Jacket			Length	Diam.	L.C.L.
		s.	d.	s.	d.				
45	100/250	42	6	64	3	B22 (Small)	238	50	140
60		52	6	77	0		300	50	170
85		63	0	92	3	B22 (Medium)	415	50	230
140		74	6	107	6		518	65	280

† Lamp Outlines are shown on pages 40 and 41.

‡ Light Output of these lamps is given on page 44.

NOTE.—Lamps should normally be used in a HORIZONTAL position, but the 45 and 60 watt sizes will operate in any position between vertical (cap up) and horizontal.

### SODIUM VAPOUR LAMPS

(see centre pages)

Sodium Vapour Electric Discharge Lamps are primarily designed for street-lighting or floodlighting and they have found application in the industrial field for the illumination of yards and other open spaces.

The lamp consists of two separate components, an inner arc tube bent into a U shape and fitted with a Bayonet Ceramic cap, and an outer envelope which is a double-walled vacuum flask. When it is necessary therefore to make a lamp replacement, as a rule only the arc tube need be replaced.

For a Sodium Vapour Electric Discharge Lamp to operate efficiently a higher-than-normal voltage must be applied to it, and for this purpose transformers with tapped primary windings to cover the normal voltage range are supplied. See pages 46 and 47.

The orange-yellow light given by the sodium vapour lamp is virtually monochromatic. The lamp gives a single line spectrum, as distinct from the continuous spectrum of the tungsten lamp and the multi-line spectrum of mercury vapour discharge lamps.



45w  
SO/H

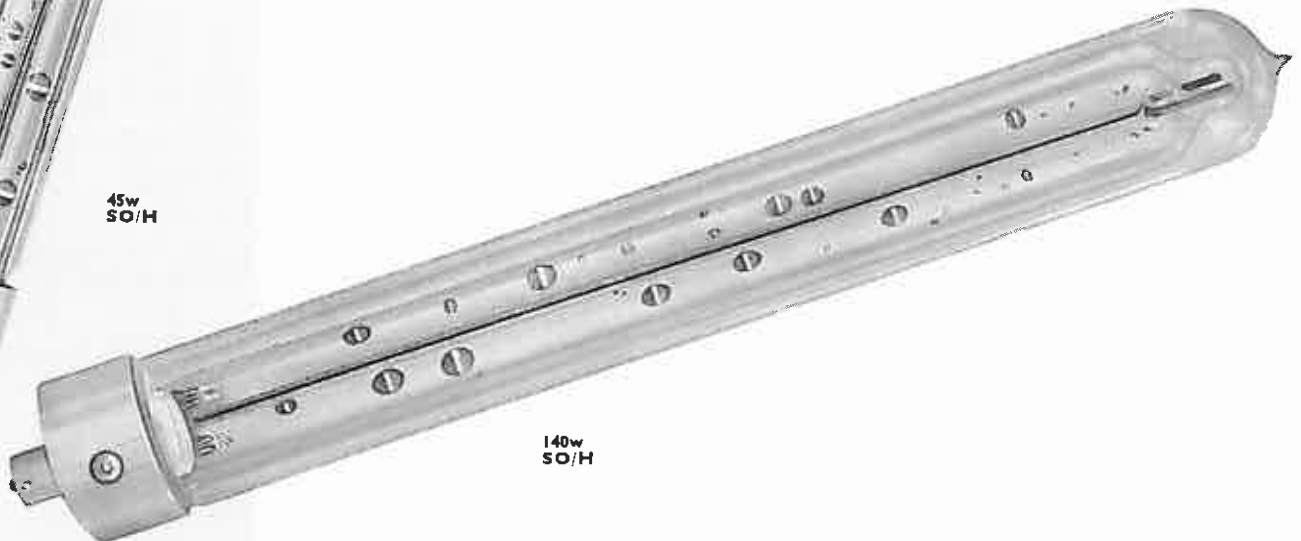

140w  
SO/H



## ULTRA VIOLET Type MBW/V (Purchase Tax not chargeable)

Watts	A.C. Volts	List Price		Cap	Approximate Dimensions			
		s.	d.		Overall Length		Diameter	
					m/m	In.	m/m	In.
125	{ 200/220 230/240 250 }	63	0	3-pin B.C. (B22/31 x 30)	178	7.00	90	3.54

## COMPACT SOURCE Type ME/D (Purchase Tax not chargeable)

Watts	A.C. or D.C. Volts	Description	List Price		Cap	Dimensions m/m		
			s.	d.		Overall Length	Diameter	L.C.L.
250	{ 200 250 }	Glass Envelope	310	0	3-pin	135 ± 3a	50 ± 2	85 ± 1
250		Box Type	430	0	P28 25	103 max.	43 x 34b	55.5 ± 0.5
250		Box Type	430	0	3-pin	130 ± 3a	64 x 55	80
250		Glass Envelope	310	0	P40.41	156 ± 3	50 ± 2	65 ± 0.5

(a) Excluding Pins. (b) With a 5.5 m/m projection on the major axis opposite the L.C.L.

### ULTRA-VIOLET LAMP (not illustrated)

This special lamp has been developed as a highly efficient source of near ultra-violet radiation with a minimum of visible light. The near ultra-violet radiation, lying just beyond the violet end of the visible spectrum, does not cause sunburning, but has power to excite fluorescence and phosphorescence in many substances and this makes it very effective in special displays. In addition, where identification is almost impossible in visible light, substances may often be easily identified by means of such fluorescence. Stains on fabrics often become strikingly evident under this radiation and it is also possible to distinguish between apparently similar materials such as natural and artificial gems.

As with other electric discharge lamps, the U.V. lamp is designed to operate on standard supply voltages with appropriate lamp auxiliary gear.

### COMPACT SOURCE LAMP

The Type ME high-pressure mercury vapour lamp consists of a quartz bulb containing two tungsten electrodes, between which an arc of high brightness burns steadily. The quartz bulb is mounted in an oval canister having an aperture in the front, through which the light emerges. The lamps are available with 3-pin caps or with prefocus caps (*not illustrated*).

Where this lamp can be operated in a separate protective housing two variants, in clear-glass outer envelopes, are also available.

The small concentrated source burns steadily with a high brightness in the region of 20,000 candles per sq.cm. The radiation has a high actinic value and the lamp operates with little deterioration of light output throughout its long life. The lamp, which should always be operated vertically base downwards, is suitable for a number of applications:—

In optical instruments such as projection microscopes for visual examination, gear profile projectors, and similar instruments.

In projection microscopes for micro-photography.

In film printers.

In lantern slide or film projectors for monochrome film.  
(It is not recommended for use with colour films.)

As a light source for examining polished metal or glass surfaces.



250w 3-pin  
GLASS ENVELOPE  
ME/D



250w 3-pin  
BOX TYPE  
ME/D

# Electric Discharge Lamps

MERCURY VAPOUR  
TYPE MBW/V, AND  
ME/D



**Mazda**  
lamps  
stay brighter longer

# LAMP OUTLINES

Dimensions in Millimetres

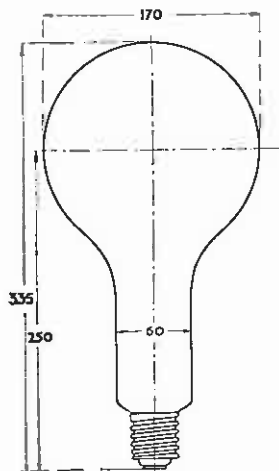

1,500w G.E.S. Cap.  
G.F. Clear

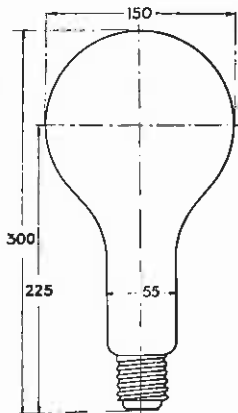

1,000 & 750w G.E.S. Cap.  
G.F. Clear

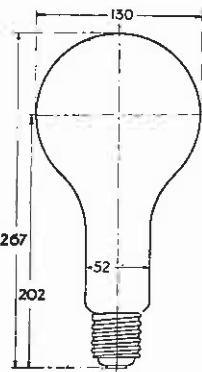

500w G.E.S. Cap.  
G.F. Clear

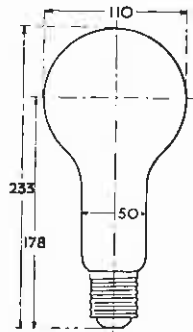

300w G.E.S. Cap.  
G.F. Clear

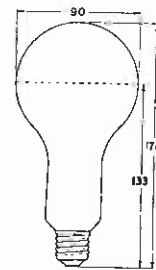

200w E.S. Cap.  
G.F. Pearl, Clear and  
Silverlight

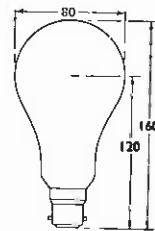

150w B.C. Cap.  
G.F. Pearl, Clear, and  
Silverlight

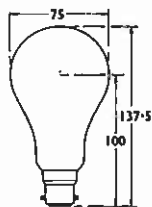

100w B.C. Cap.  
Pearl, G.F. Clear,  
Colled-Coil, and  
Silverlight

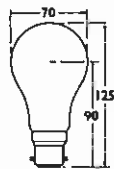

75w B.C. Cap.  
Pearl, Clear, and  
Colled-Coil

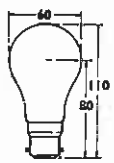

40w & 60w B.C.  
Cap. Pearl, G.F.  
Clear, G.F. Traction,  
Colled-Coil,  
and Silverlight

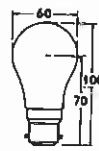

25w B.C. Cap.  
Pearl, G.F. Clear,  
Vac. Clear

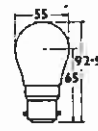

15w B.C. Cap.  
Pearl, Vac.  
Clear

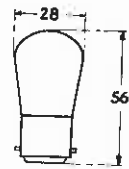

15w B.C. Cap.  
Pigmy Sign Bulb

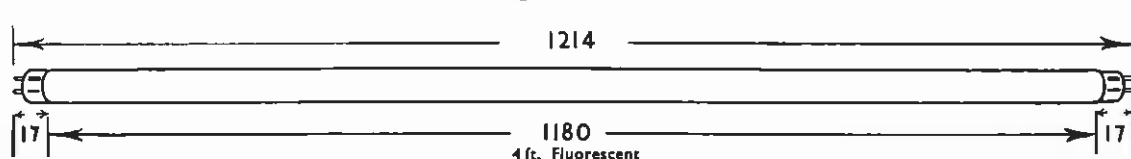

4 ft. Fluorescent

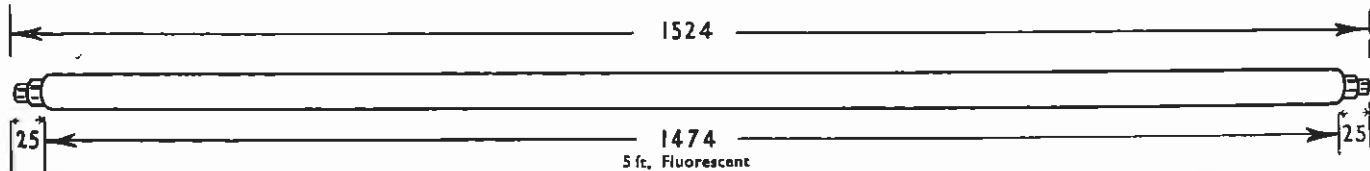

5 ft. Fluorescent

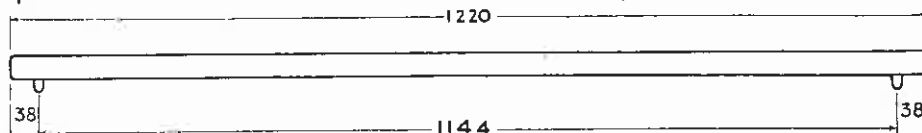

150w Straight Light Tube

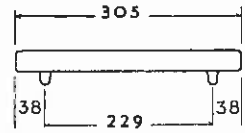

35w Straight Light Tube

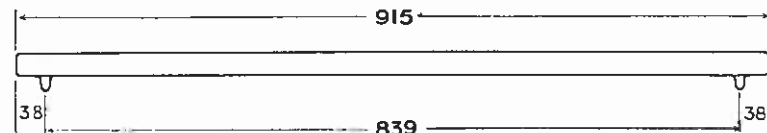

110w Straight Light Tube

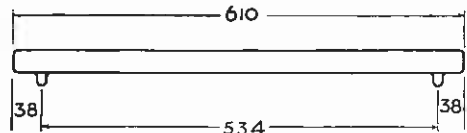

75w Straight Light Tube

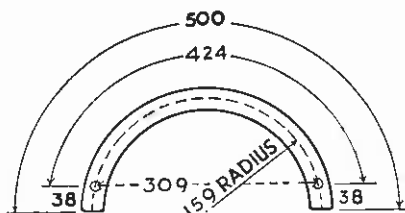

60w Circle Light Tube

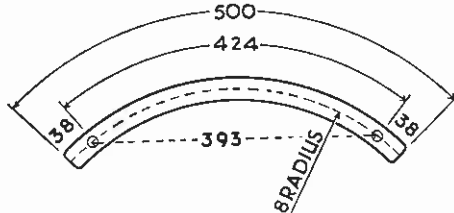

60w Circle Light Tube

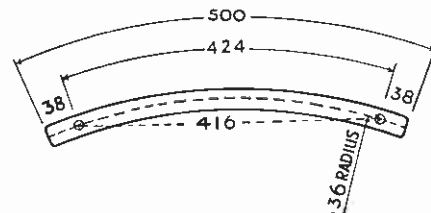

60w Circle Light Tube

# LAMP OUTLINES

Dimensions in Millimetres.

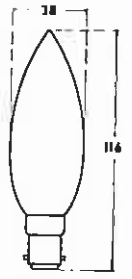

25w S.B.C. Cap  
Plain Candle

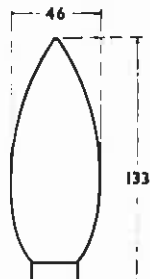

40w or 60w S.B.C.  
Cap. Plain Candle

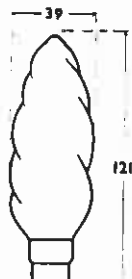

25w S.B.C. Cap.  
Twisted Candle

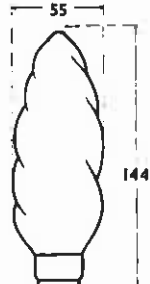

60w S.B.C. Cap.  
Twisted Candle

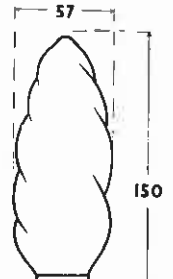

40w S.B.C. Cap.  
Twisted Candle

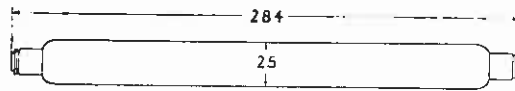

30w and 60w C.C. Cap. Double Capped Tubular

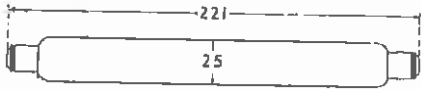

30w C.C. Double Capped Tubular

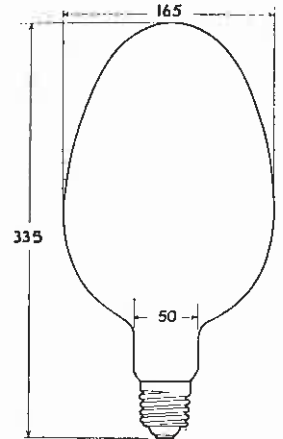

400w G.E.S. Cap.  
Mercury Vapour  
with Fluorescent  
Iso-thermal Bulb  
(MAF/V)



25w S.B.C.  
Single Capped  
Tubular

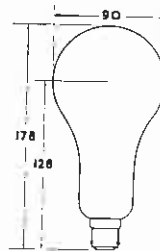

125w  
3-pin B.C. Cap. Mercury  
Vapour (MB/V or MBF/V)  
and Mercury Vapour with  
Ultra-Violet Filter Bulb.

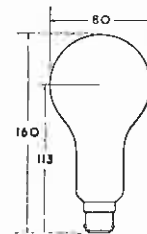

80w  
3-pin B.C. Cap.  
Mercury Vapour  
(MB/V or MBF/V)

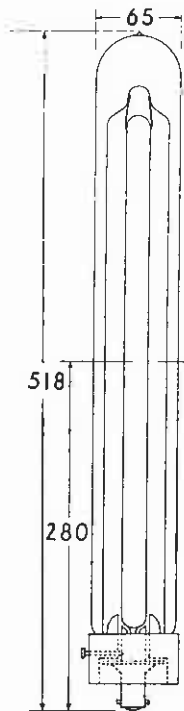

140w B.C.  
Ceramic Cap.  
Sodium Vapour  
(SO/H)



85w B.C.  
Ceramic Cap  
Sodium Vapour  
(SO/H)

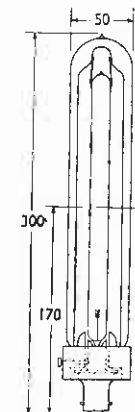

60w B.C.  
Ceramic Cap  
Sodium Vapour  
(SO/H)

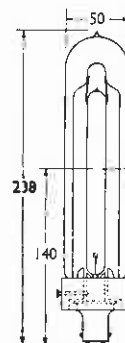

45w B.C.  
Ceramic Cap  
Sodium Vapour  
(SO/H)



250w  
G.E.S. Cap.  
Mercury Vapour  
(MA/V)

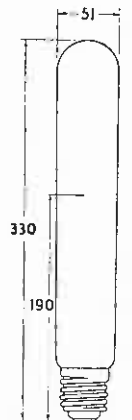

400w  
G.E.S. Cap  
Mercury Vapour  
(MA/V or MA/U)

# LAMP CAPS

The illustrations are approximately half full size with normal dimensions in millimetres.

## BAYONET CAPS Double Contact (B.C.)

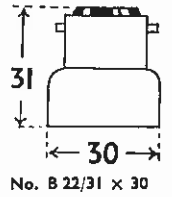
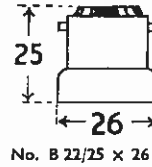
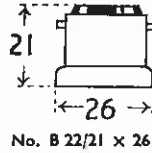
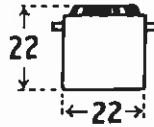
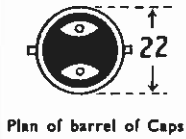

## Centre Contact (C.C.)

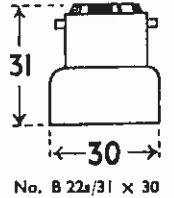
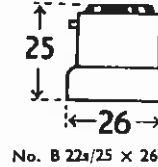
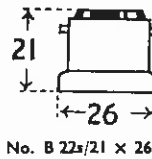
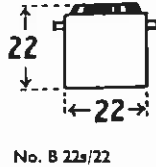
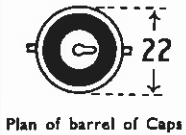

## SMALL BAYONET CAPS

### Double Contact (S.B.C.)

### Miniature Centre Contact (M.C.C.)

### Centre Contact (S.C.C.)

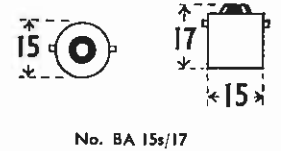
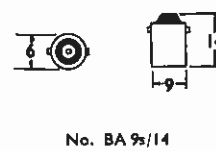
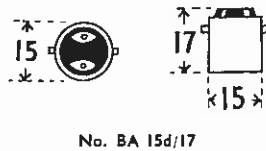
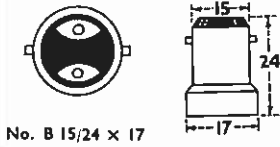

## BOSCH CAPS

### Double Contact

### Centre Contact

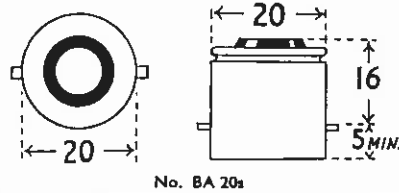
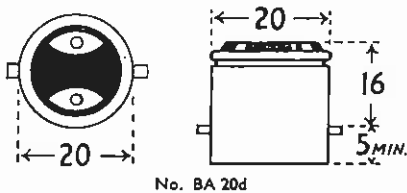

## THREE PIN BAYONET CAP

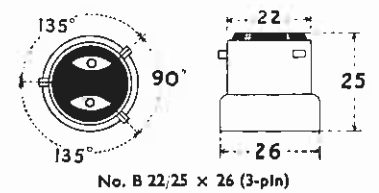

## EDISON SCREW CAPS Goliath (G.E.S.)

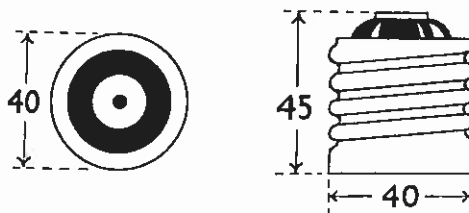

### Standard (E.S.)

### Miniature (M.E.S.)

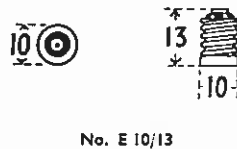
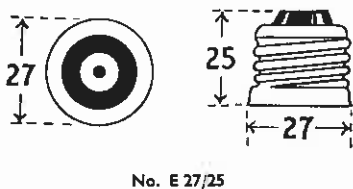

## MINERS' HANDLAMP CAPS

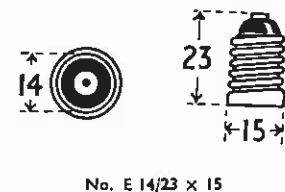
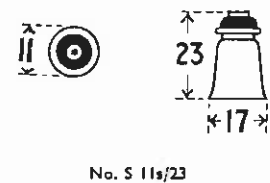

# LAMP CAPS (contd.)

## CAPS FOR DOUBLE-ENDED TUBULAR LAMPS

### Centre Contacts



No. S 15a

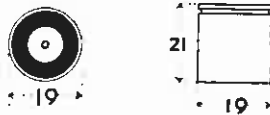

No. S 19a

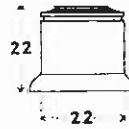

No. S 22a

### Clip Contacts



No. S 15

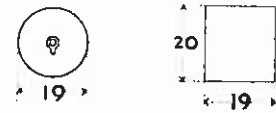

No. S 19

### HOLLOW TUBULAR CAP

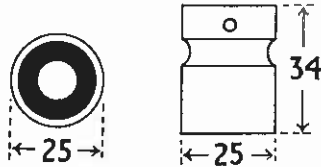

### THREE PIN CENTRE CONTACT CAP (3-pin C.C.)

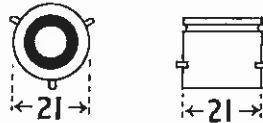

No. BA. 21s (3-pin)

### FESTOON LAMP CAPS

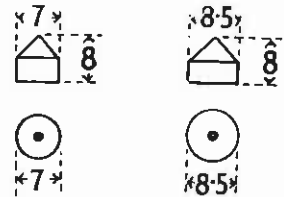

No. S 7/8

No. S 8-5/8

### MEDIUM BI-PIN 35

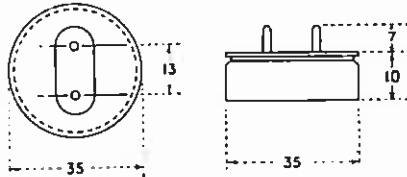

(G 2-4 x 13/35 x 10)

### MEDIUM BI-PIN 23

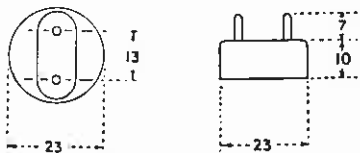

(G 2-4 x 13/23 x 10)

### PRE-FOCUS CAPS

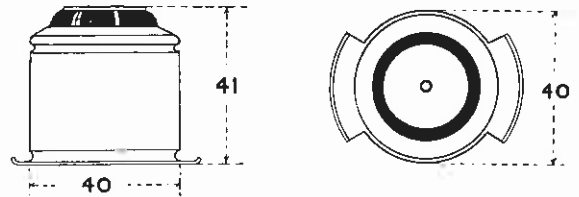

No. P 40/41

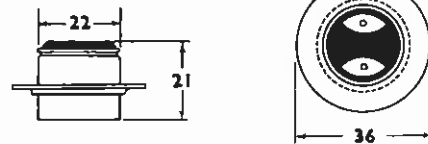

No. P 22d/21



No. P 28/25

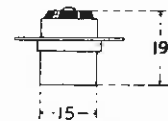

No. P 15/19

### RAISED CONTACT

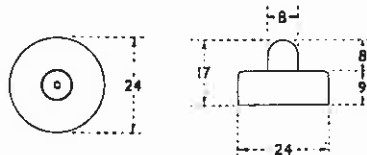

S 24a/17

# LAMP EFFICIENCIES

## G. L. S. CLEAR & PEARL

Listed on pages 8 & 9

Lamps Watts	Voltage Range and Approximate Initial Total Lumens Output				
	200-260	100-130	60-75	35-55	25
15	120	140	—	150	165
25	220	240	260	280	310
40	*430	470	470	500	550
60	*725	790	780	820	890
75	*960	1060	—	—	—
100	*1380	1500	1460	1510	1600
150	2150	2360	2330	2400	—
200	2960	3280	3240	3350	—
300	4690	5250	5170	5330	—
500	8410	9500	9340	9570	—
750	13500	15150	14800	15130	—
1000	18900	20900	20600	20830	—
1500	30100	32200	—	—	—

\*Coiled Coil.

## SILVERLIGHT

Listed on page 10

Lamp Watts	Approximate Initial Total Lumens Output 200/260 volts
<b>COILED COIL</b>	
40	410
60	690
100	1310
<b>SINGLE COIL</b>	
40	330
60	550
100	1050
150	2045
200	2810

## FLUORESCENT LAMPS

(MCF/U) Listed on pages 12 & 13

Lamp Watts	Nominal Length	Colour †	LUMENS Average for first 5000 hours
80	5 ft.	D or W W	3600
		N	2700
125	8 ft.	CM or M	2200
		N	5000
40	4 ft.	D or W, W	1920
		N	1500
40	2 ft.	CM or M	1200
		W/W	1080
30	3 ft.	N	920
		M	760
20	2 ft.	W W	1200
		N	1020
15	1½ ft.	M	840
		W W	660
		N	580
		M	460
		W/W	470
		N	390
		M	330

† D = Daylight, N = Natural, W/W = Warm-White, CM = Colour-matching, M = Mellow.

## PHOTOGRAPHIC LAMPS

Listed on page 16

Lamp Watts	Voltage	Initial Light Output Lumens
<b>PHOTO FLOOD</b>		
275	100/110, 200/210	9350
	220/230, 240/250	17500
500	100/110, 200/210	17000
	220/230, 240/250	17500
1000	110	33000
<b>PHOTO PEARL</b>		
500	100/130, 200/260	11250
<b>PHOTO ENLARGER (Inside Silica-coated)</b>		
150	210, 230, 250	2100 approx.

## MERCURY VAPOUR LAMPS

Lamp Watts	Voltage	Initial Light Output Lumens
<b>TYPE MA/V (Listed on page 36)</b>		
250	100/130	8500
	200/250	8750
400	100/130	16000
	200/250	16800
<b>TYPE MA/U (Listed on page 36)</b>		
250	200/250	8000
400	200/250	15200
<b>TYPE MAF/V (Listed on page 37)</b>		
400	200/250	15200
<b>TYPE MB/V (Listed on page 36)</b>		
80	200/250	3000
		5300
125		

## MERCURY VAPOUR LAMPS

Lamp Watts	Voltage	Initial Light Output Lumens
<b>TYPE MBF/V (Listed on page 37)</b>		
80	200/250	3000
		5300
125		

## SODIUM VAPOUR LAMPS

Listed on page 38

Lamp Watts	Voltage	Initial Light Output Lumens
45	100/250	2700
		4200
		6460
		10640
60		
85		
140		

CATALOGUE No.	DESCRIPTION
<b>C 69119</b>	G.E.S. Unskirted (BTH Patent) (Tungsten Lamps)
<b>C 69120</b>	G.E.S. Skirted (BTH Patent) (Tungsten Lamps)
<b>C 76551</b>	B.C. Rubber Sleeve (Fluorescent Lamps)
<b>C 77969</b>	Medium Bi-pin Rubber Sleeve (Fluorescent Lamps)
<b>C 78679</b>	Medium Bi-pin Compact (Fluorescent Lamps)
<b>C 82856</b>	Fixed B.C. (Fluorescent Lamps)
<b>C 83024</b>	B.C. Rubber Sleeve for Sodium Lamps
<b>C 83145</b>	Medium Bi-pin (White) (Fluorescent Lamps)
<b>F 2010</b>	B.C. with Anti-Flicker Shield (Fluorescent Lamps)
<b>M 252</b>	For ME/D lamps
<b>C 84079</b>	BI-post (Studio Spotlights)

# Mazda Lampholders

*Prices on application*



C 76551

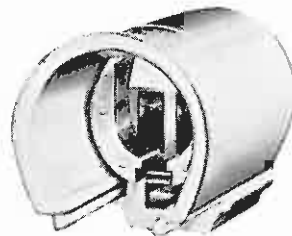

C 82856



F 2010



C 84079



M 252



C 69119



C 69120

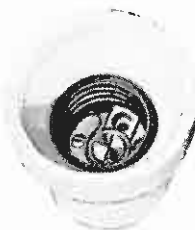

C 77969



C 83145



C 83024

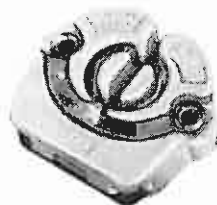

C 78679





A



B



C

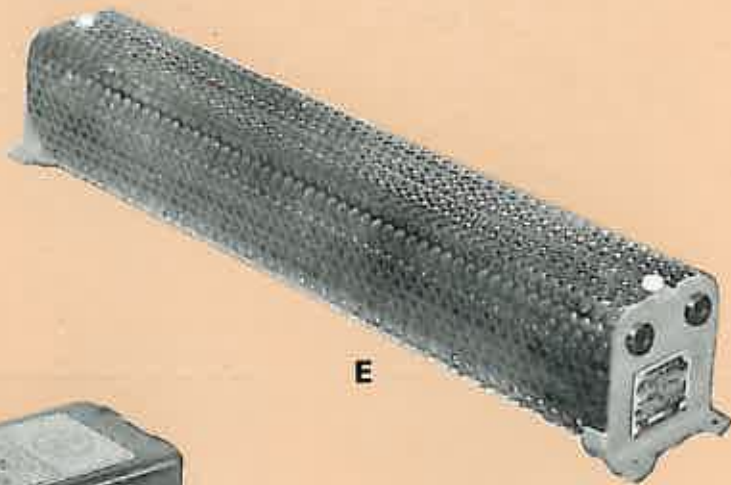

E



D



F



G



H



I



J



# MAZDA LAMP AUXILIARY GEAR

Prices and full details on application.

For illustrations see opposite page

## (A) CHOKES

for use with mercury vapour lamps (pages 36, 37 & 39\*)

Catalogue No.	A.C. 50 Cycles Supply Voltages	Lamp Watts
MRG 501	190/230	400 MA
MRG 502	215/255	400 MA
MRG 503	190/230	250 MA
MRG 504	215/255	250 MA
MRG 505	190/230	125 MB
MRG 506	215/255	125 MB
MRG 507	190/230	80 MB
MRG 508	215/255	80 MB
MRG 509	100/120	400 MA
MRG 510	100/120	250 MA

\* Special Choke Cat. No. MRG 101 must be used with 250 watt ME/D lamp.

## (B) TRANSFORMERS

for use with sodium vapour lamps (page 38)

Catalogue No.	A.C. 50 Cycles Supply Voltages	Lamp Watts
MCG 101	190/220	140
MCG 102	220/250	140
MCG 103	190/220	45/60/85
MCG 104	220/250	45/60/85

## (C) CUBIC CAPACITORS

for use with electric discharge lamps (pages 36—39).

Catalogue No.	Capacity	Catalogue No.	Capacity
C 82595	mfd. 8	C 82604	mfd. 60
C 82596	10	C 82605	70
C 82597	13	C 82606	80
C 82598	15	C 82607	90
C 82599	20	C 82608	100
C 82600	25	C 82609	120
C 82601	30	C 82610	140
C 82602	40	C 82611	160
C 82603	50		

## (D) CHOKES

for use with fluorescent lamps (pages 12 and 13)

Catalogue No.	Dimensions				Weight lb.
	Length In.	Width In.	Height In.	Fixing Centres In.	
MRJ 101	6½	3½	2½	5½	6½
MRJ 102	6½	3½	2½	5½	6½
MRJ 103	6½	3½	2½	5½	6½
MRJ 104	6½	3½	2½	5½	6½
MRJ 105	6½	3½	2½	5½	6½
MRJ 106	6½	3½	2½	5½	6½
MRJ 201	5½	2½	2	5½	4
MRJ 202	5½	2½	2	5½	4
MRJ 203	5½	2½	2	5½	4
MRJ 204	5½	2½	2	5½	4
MRJ 205	5½	2½	2	5½	4
MRJ 215	5½	2½	2	5½	4
MRJ 216	5½	2½	2	5½	4
MRJ 217	5½	2½	2	5½	4
MRJ 218	5½	2½	2	5½	4
MRJ 219	5½	2½	2	5½	4
MRJ 220	5½	2½	2	5½	4
MRJ 221	5½	2½	2	5½	4
MRJ 222	5½	2½	2	5½	4

## (E) RESISTORS

for use with fluorescent lamps (pages 12 and 13) on D.C. supplies †

Lamp Watts	Choke	Starter	Resistor Type AF					
			200v.	210v.	220v.	230v.	240v.	250v.
80 (5 ft.)	MRJ 101	ST 15	2051	2052	2053	2054	2055	2055
40 (4 ft.)	MRJ 201	ST 24	2057	2058	2059	2060	2061	2061
30 (3 ft.)	MRJ 201	ST 25	2059	2060	2061	2062	2063	2063
40 (2 ft.) 2 In series	MRJ 101	ST 15	2052	2053	2054	2054	2055	2055
20 (2 ft.) 2 In series	MRJ 201	ST 25	2056	2057	2058	2059	2060	2061
15 (1½ ft.) 2 In series	MRJ 201	ST 25	2058	2059	2060	2061	2062	2062

† A reversing switch Cat. No. E 1951 can also be supplied for use with Fluorescent Lamps on D.C. supplies.

## (F) TRANSFORMERS

for use with fluorescent lamps (pages 12 and 13) on low voltage supplies

Catalogue No.	A.C. 50 Cycles Input Voltage	Lamp Watts
MC 188	110/115	80
MC 189	110/115	{ 40 (4 ft.) 30

## (G) INSTANT START BALLAST

for use with Instant Start fluorescent lamps (pages 12 and 13)

Cat. No.	Lamp Watts	A.C. 50 cycles Supply Voltage	Overall Length In.	Overall Width In.	Overall Height In.	Fixing Centres In.	Approx. Weight lb.
MK 108	80	200/210	10½	3¾	2½	9½	10
MK 109	80	220/230	8½	3¾	2½	8½	8½
MK 110	80	230/240	8½	3¾	2½	8½	8½
MK 116	80	240/250	8½	3¾	2½	8½	8½
MK 112	40	200/210	8¾	2½	2	7½	7
MK 113	40	220/230	8¾	2½	2	7½	7
MK 114	40	230/240	8¾	2½	2	7½	7
MK 115	40	240/250	8¾	2½	2	7½	7

## (H) STARTER SOCKET

for use with fluorescent lamps (pages 12 and 13)

Catalogue No. C 77592

## (I) CAPACITORS

for use with fluorescent lamps (pages 12 and 13)

Catalogue No.	Capacitance	Max. Working Voltage	Lamp Watts	
			Single	Double
PL 11C	7.5 mfd.	260	80	{ 40 (4 ft.) 40 (2 ft.) 30 30
PJ 12	3.25 mfd.	260	{ 40 (4 ft.) 30 20 15	15
PJ 13	4.5 mfd.	260		—
PJ 51	7.0 mfd.	400	—	80

## (J) STARTERS

for use with fluorescent lamps (pages 12 and 13)

Lamp Watts	Catalogue Number A.C./D.C.
80 watt 60"	ST 23
40 watt 48"	ST 24
30 watt 36"	ST 25
40 watt 24"	ST 23
20 watt 24"	ST 25
15 watt 18"	ST 25

# Mazda Fluorescent Fittings

The fittings illustrated on these pages are selected from the complete range of Mazda Fluorescent Fittings designed for every type of Industrial, Commercial, and Decorative Lighting. Prices and full details of these and other lighting fittings will be supplied on application.

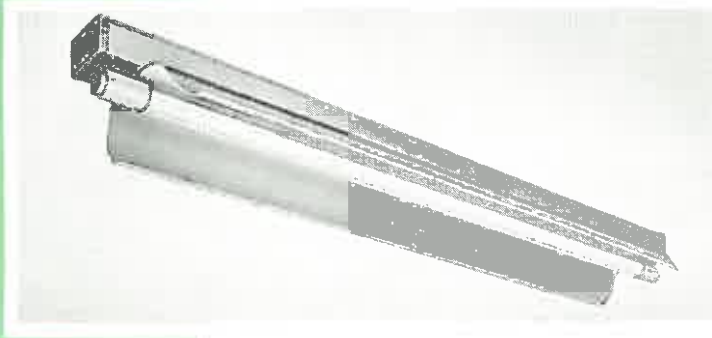

F 1160/1/8060



**Mazda**  
lamps  
stay brighter longer



F 1160/2/8060

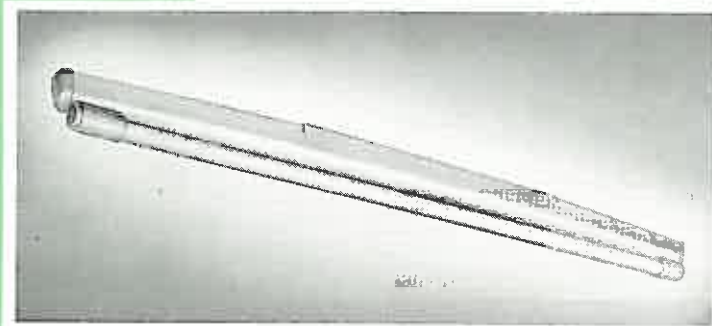

F 1004/1/8060



1060,2/8060

Also available with single lamp

# Mazda Fluorescent Fittings

The BTH Company are also leaders in the design of special decorative and functional fittings to cater for individual tastes or particular requirements not fully covered by the standard range, and BTH Engineers, with their wide experience, will always be pleased to give expert advice on any lighting problem.

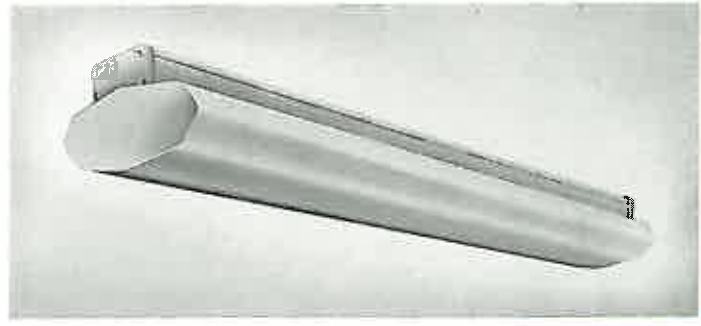

F 1234/1/8060



F 1130/1/8060  
"Flameproof"

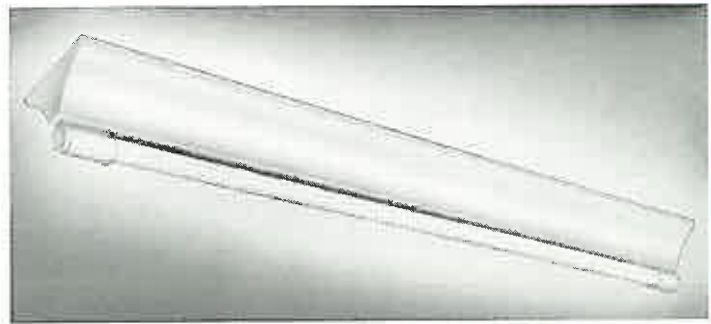

F 1080/1/8060



F 207/1/8060

Normally supplied without "Perspex" Closure.

# Mazda 'Rugby' Range Reflectors & Fittings

FOR USE WITH TUNGSTEN  
OR MERCURY VAPOUR LAMPS

The fittings on this page represent only a small fraction of the complete range of Mazda Equipment for interior lighting of all kinds. Full details and prices of these and other fittings will be supplied on application.

KEY	DESCRIPTION
A	Dispersive Reflector
B	Dust-free Concentrating Reflector
C	45° Angle Reflector
D	Elliptical Angle Reflector
E	Vertical Elliptical Reflector
F	Glassteel Diffuser
G	Mercury Vapour Fitting (Available with or without magnetic arc control)
H	Dispersive Heavy Dustproof
I	Bulkhead Fitting



A



B



E



F



C



D



H



I



G

# Mazda Streetlighting Lanterns & Floodlights

The Lanterns and Floodlights illustrated on this page are selected from the comprehensive range of Mazda Fittings designed to meet every outdoor lighting requirement. Full details and prices of this and other outdoor lighting equipment will be supplied on application.

KEY	DESCRIPTION
A	Fluorescent Lantern
B	Sodium Enclosed Lantern
C	Sodium Open Lantern
D	Slide Entry Mercury Lantern
E	Parish Lantern
F	Horizontal Mercury Lantern (Sapphire)
G	"Nine" Floodlight
H	"Three" Floodlight

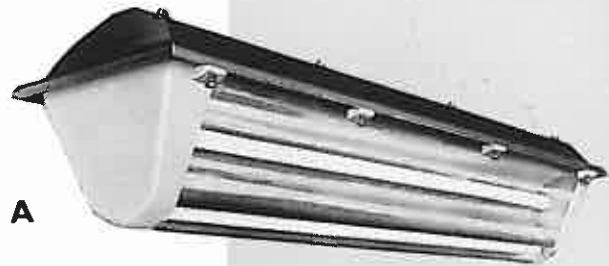

A

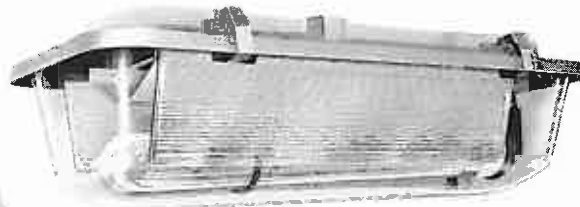

B

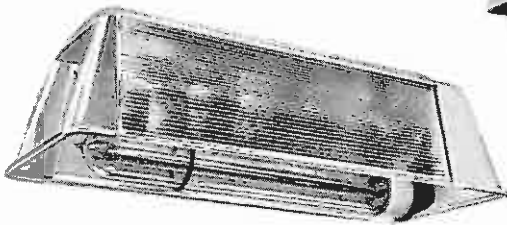

C



F



D

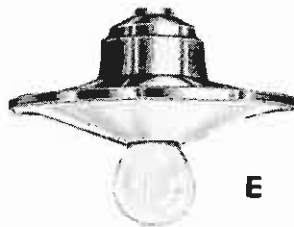

E

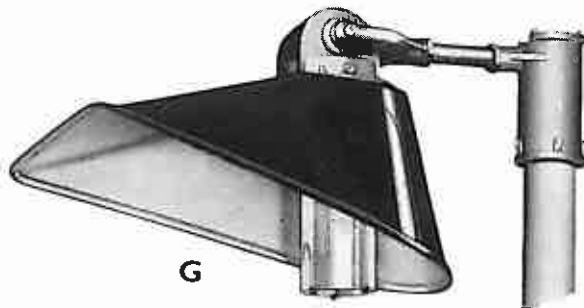

G



H

# These Mazda Lamp Publicat

*7 good reasons why*

**Mazda**  
FLUORESCENT LAMPS

*stay brighter longer*

If you still  
put away your camera  
when you go indoors  
read this  
**Mazda**  
Booklet on photoflash bulbs

**Mazda**

ELECTRIC  
DISCHARGE  
LAMPS

THE LAMPS WITH BEHIND THEM

THE BRITISH THOMSON-HOUSTON CO. LTD., CRICK WOOD, ALDREYCH, W.C.2

**Some neck!**

*Just one  
reason why*  
**Mazda**  
*lamps stay brighter longer*

**Mazda**  
Coloured lamps and floodlights

THE BRITISH THOMSON-HOUSTON CO. LTD., CRICK WOOD, ALDREYCH, W.C.2

**DEALERS' GUIDE**

**Mazda**  
CAR BULBS

**stay  
brighter  
longer**

FOR MOTOR CYCLE  
MOTOR CARS and  
COMMERCIAL  
VEHICLES

THE LAMPS WITH BEHIND THEM

ons are available on request



**Mazda**  
PROJECTOR, PHOTOGRAPHIC  
AND SPECIAL PURPOSE LAMPS

PRECISION - BUILT FOR  
ACCURATE FOCUSING

 THE BRITISH THOMSON-HOUSTON CO., LTD., CROWN HOUSE, ALDWYCH, W.C.1.

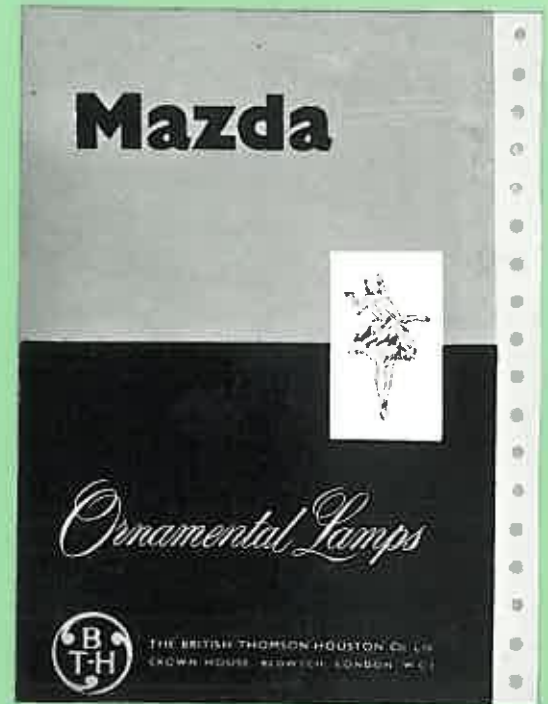

**Mazda**



*Ornamental Lamps*

 THE BRITISH THOMSON-HOUSTON CO., LTD.  
CROWN HOUSE, REDWICH, LONDON, W.C.1.



**Mazda**

XENON FLASH TUBES



THE BRITISH THOMSON-HOUSTON CO., LTD.  
CROWN HOUSE, ALDWYCH, LONDON, W.C.1.



*the new lamp  
with 100 uses*

**Mazda** REFLECTOR SPOTLIGHT



THE BRITISH THOMSON-HOUSTON CO., LTD., CROWN HOUSE, ALDWYCH, LONDON, W.C.1.



**Mazda** CAR BULBS



stay  
brighter  
longer

FOR MOTOR CARS,  
MOTOR CYCLES AND  
COMMERCIAL VEHICLES

THE BRITISH THOMSON-HOUSTON CO., LTD.

# THE BRITISH THOMSON-HOUSTON COMPANY, LTD.

*Electrical Engineers and Manufacturers*

LONDON - - - - - Crown House, Aldwych, W.C.2  
Telephone : Temple Bar 8040      Telegrams : Asteroidal, Estrand, London

## LIGHTING DEPARTMENT HEADQUARTERS

44 Fitzroy Road, N.W.1 - - - - - Primrose 7750-62

## LAMP & LIGHTING TRADE COUNTERS AND LIGHTING ADVISORY SERVICE

*Technical Advice and Information may be obtained through any of the following Offices :*

BELFAST ..	12 Alfred Street. Belfast 29368/9	LEEDS, 1 ..	.. 46 Wellington Street. Leeds 31541
BIRMINGHAM ..	Geoffrey Buildings, John Bright Street. Midland 6335	LEICESTER ..	.. 5 Campbell Street. Granby 291/2
BLACKBURN ..	"Old Bank," Old Bank Street, King Street. Blackburn 7093	LEYTONSTONE ..	220 High Road, Leytonstone, E.11 Maryland 4784/5
BLACKPOOL ..	8-9 Cowley Road, Marton. South Shore 41422	LIVERPOOL, 1 ..	27-29 Stanley Street. Central 5721
BOURNEMOUTH	511 Roumelia Lane, Boscombe. Boscombe 34194	LONDON ..	.. Crown House, Aldwych, W.C.2. Temple Bar 1343 or 44 Fitzroy Road, N.W.1 Primrose 7750-62
BRISTOL, 1 ..	119 Victoria Street. Bristol 20111	MANCHESTER, 3	15 Quay Street, Deansgate. Blackfriars 2691
CAMBRIDGE ..	Fellowship House, 133 Fitzroy St. Cambridge 54370 & 57366	MIDDLESBROUGH	Post Office Buildings, Marton Road. Middlesbrough 2476
CARDIFF ..	Jotham's Buildings, 26-27 St. Mary Street. Cardiff 32291/3	NEWCASTLE-ON- TYNE, 1	9 Higham Place. Newcastle 25040
CHELTENHAM ..	17 Grosvenor Street. Cheltenham 2776	NORTHAMPTON	College Street. Northampton 2981
CHESTER ..	5 Boughton. Chester 20813	NORWICH ..	St. Michael's Chambers, St. Andrew St. Norwich 22541
COLCHESTER ..	Culver Street. Colchester 2843	NOTTINGHAM ..	71-73 Lower Parliament Street. Nottingham 43588/9
CROYDON ..	54 Selsdon Rd., Sth. Croydon. Croydon 5633	OXFORD ..	90 St. Aldates. Oxford 4170
DUBLIN ..	Mazda House, 25 Suffolk Street. Dublin 77379/70	PLYMOUTH ..	Chapel Street, Regent Street. Plymouth 61915
DUNDEE ..	17 Baltic Street. Dundee 5600	PORTSMOUTH ..	54 St. Vincent Street. Southsea. Portsmouth 4383
EDINBURGH, 2 ..	130 George Street. Central 6922	READING ..	74 Oxford Road. Reading 2700
EXETER ..	Post Office Chambers, 83/84 Queen St. Exeter 55749	SHEFFIELD, 1 ..	Mazda Buildings, Campo Lane. Sheffield 23086
GLASGOW, C.2 ..	53 Pitt Street. Central 4331	SOUTHAMPTON ..	33 Carlton Crescent. Southampton 3369
GUILDFORD ..	Bedford House, Bedford Rd. Guildford 2788	STOKE-ON-TRENT	King's Chambers, Kingsway. Stoke-on-Trent 48768
HASTINGS ..	17 Dorset Place. Hastings 2734	SWANSEA ..	12/13 The Kingsway. Swansea 2151
HUDDERSFIELD	7 Brook Street. Huddersfield 3291		
HULL ..	2 Prince's Dock Chambers, Prince's Dock Street. Central 36241		





# READY RECKONER

1		2		3		4		5		6		7		8		9		10		11		12		20		25		50					
s.	d.	s.	d.	s.	d.	s.	d.	s.	d.	s.	d.	s.	d.	s.	d.	s.	d.	s.	d.	s.	d.	s.	d.	s.	d.	s.	d.	s.	d.	s.	d.	s.	d.
1	2	3	4	5	6	7	8	9	10	11	12	20	25	50																			
2	4	6	8	10	12	14	16	18	20	22	24	26	28	30	32	34	36	38	40	42	44	46	48	50	60	75	100	125	150	200			
3	6	9	12	15	18	21	24	27	30	33	36	39	42	45	48	51	54	57	60	63	66	69	72	80	100	125	150	175	200	250			
4	8	12	16	20	24	28	32	36	40	44	48	52	56	60	64	68	72	76	80	84	88	92	96	100	125	150	175	200	250	300			
5	10	15	20	25	30	35	40	45	50	55	60	65	70	75	80	85	90	95	100	105	110	115	120	125	150	175	200	250	300	350			
6	12	18	24	30	36	42	48	54	60	66	72	78	84	90	96	102	108	114	120	126	132	138	144	150	175	200	250	300	350	400			
7	14	21	28	35	42	49	56	63	70	77	84	91	98	105	112	119	126	133	140	147	154	161	168	175	200	250	300	350	400	450			
8	16	24	32	40	48	56	64	72	80	88	96	104	112	120	128	136	144	152	160	168	176	184	192	200	250	300	350	400	450	500			
9	18	27	36	45	54	63	72	81	90	99	108	117	126	135	144	153	162	171	180	189	198	207	216	225	250	300	350	400	450	500			
10	20	30	40	50	60	70	80	90	100	110	120	130	140	150	160	170	180	190	200	210	220	230	240	250	300	350	400	450	500	550			
11	22	33	44	55	66	77	88	99	110	121	132	143	154	165	176	187	198	209	220	231	242	253	264	275	300	350	400	450	500	550			
12	24	36	48	60	72	84	96	108	120	132	144	156	168	180	192	204	216	228	240	252	264	276	288	300	350	400	450	500	550	600			
13	26	39	52	65	78	91	104	117	130	143	156	169	182	195	208	221	234	247	260	273	286	299	312	325	350	400	450	500	550	600			
14	28	42	56	70	84	98	112	126	140	154	168	182	196	210	224	238	252	266	280	294	308	322	336	350	400	450	500	550	600	650			
15	30	45	60	75	90	105	120	135	150	165	180	195	210	225	240	255	270	285	300	315	330	345	360	375	400	450	500	550	600	650	700		
16	32	48	64	80	96	112	128	144	160	176	192	208	224	240	256	272	288	304	320	336	352	368	384	400	450	500	550	600	650	700	750		
17	34	51	68	85	102	119	136	153	170	187	204	221	238	255	272	289	306	323	340	357	374	391	408	425	450	500	550	600	650	700	750		
18	36	54	72	90	108	126	144	162	180	198	216	234	252	270	288	306	324	342	360	378	396	414	432	450	500	550	600	650	700	750	800		
19	38	57	76	95	114	133	152	171	190	209	228	247	266	285	304	323	342	361	380	399	418	437	456	475	500	550	600	650	700	750	800		
20	40	60	80	100	120	140	160	180	200	220	240	260	280	300	320	340	360	380	400	420	440	460	480	500	550	600	650	700	750	800	850	900	

# STANDARD PACKING QUANTITIES

Lamps are supplied packed in the quantities stated below.

Type of Lamp	Page	Wattages and Packing Quantities													
		15 watt	25 watt	40 watt	60 watt	75 watt	100 watt	150 watt	200 watt	250 watt	300 watt	500 watt	750 watt	1000 watt	1500 watt
G.L.S. Single-coil, Clear	8	50	50	50	50	50	50	50	25		12	9	6	6	4
G.L.S. Single-coil, Pearl	9	50	50	50	50	50	50	50	25						
G.L.S. Coiled-coil, Clear and Pearl	8, 9			50	50	50	50								
Silverlight	10			50	50		50	50	25						
Reflector Type Lamps (Spotlight and Floodlight) (Infra-red)	11 27					24		6		6					
Tubular Lamps	15	25	25												
Longlite	15			25	25										
Plain and Twisted Candle	15		24	24	24										
All fluorescent lamps up to and including 80 watt No. 5 and S.M. No. 22 50 m/m Headlamps (Except Bosch Caps) 28 m/m Prefocus Headlamps 38 m/m Headlamps (Except Bosch Caps) 25 m/m Stop Lamps 18 m/m Side, Tail & Dash	12	Packed in quantities of 25.													
	17	Packed in quantities of 72.													
	17	Packed in quantities of 50.													
	30	Display cartons of 12, or 72 in corrugated outer carton.													
	30 & 31	Display cartons of 12, or 1 gross in corrugated outer carton.													
32	Display cartons of 12 or 2 gross in corrugated outer carton.														

### DELIVERY CONDITIONS

Packing and delivery of lamps is free of charge. The British Thomson-Houston Co., Ltd., will credit or replace lamps broken in transit between their store and the customer's premises provided they are advised at once and the lamps returned, carriage paid, within seven days of date of dispatch, the Company's dispatch note number to be quoted. The Company will not accept responsibility for safe custody of such returned lamps. Claims for transportation and breakage allowance can be entertained by the Company only on their own consignments.





